



Collibra for Desktop
User Guide

Collibra for Desktop

User Guide

Revision: 24 May 2022

You can find the most up-to-date technical documentation online at

<https://productresources.collibra.com/docs/collibra4desktop/1.10>

Contents

Contents	ii
New and updated topics in 1.9	vi
What is Collibra for Desktop?	1
Installing Collibra for Desktop	2
Install Collibra for Desktop on macOS	3
Install Collibra for Desktop on Windows	4
Updating Collibra for Desktop	6
Unattended app configuration on macOS	8
Unattended installation on Windows	9
Configuration file	12
Logging	13
Sign in to Collibra for Desktop	16
Switch environments	18
Collibra for Desktop user interface	20
User interface	21
Asset details	22
Community assets	24
Domain assets	25
Table assets	27
Column assets	28
Searching with Collibra for Desktop	30
About Collibra for Desktop Search	30
Discover	34

Search for assets	36
Filtering search results	37
Wildcards and symbols for searching	39
Share search queries	40
Working with assets	42
Working with tags	43
Export to PDF	44
Open an asset in Collibra Data Intelligence Cloud	44
Diagram pictures	45
Share an asset	46
Open a shared link	47
Working with comments	50
Add a comment	50
Edit a comment	50
Delete a comment	51
Comments formatting options	52
Working with workflows	54
Starting workflows	55
Working with tasks	57
Reassign a task	59
Cancel a task	60
Ratings	62
Enabling ratings	62
Permissions	62
View ratings	63
Rate an asset	63

Edit your ratings	64
Delete your ratings	65
Tableau assets	66
Tableau operating model	67
Tableau assets	68
Power BI assets	70
Power BI operating model	71
Power BI assets	72
Looker assets	74
Looker operating model	75
App settings	78
Settings in Collibra for Desktop	78
Settings in Collibra Console	81
Set the search keyboard shortcut	86
Change the Collibra for Desktop colors	88
Add your own logo to the sign-in window	89

New and updated topics in 1.9

- You can [edit](#) the colors of Collibra for Desktop to make the app correspond more with your company's brand.
- You can [replace](#) the Collibra logo on the sign-in page.
- Most of the [settings](#) are only available in Collibra Console of your environment.
- Most of the preconfiguration options ([macOS](#) and [Windows](#)) are only available in Collibra Console of your environment.



What is Collibra for Desktop?

Collibra for Desktop is an application that allows you to interact with Collibra Data Intelligence Cloud, for example search for resources from within your browser or favorite applications. It provides a simple user interface for users who are not familiar with Collibra.

Note

Collibra for Desktop replaces Collibra Everywhere for macOS and Collibra Everywhere for Windows which are deprecated.

Collibra Platform 5.7.x will be the last version of the platform to be compatible with Collibra Everywhere for macOS and Collibra Everywhere for Windows

You can access the following resources:

- Assets
- Communities
- Domains
- Users
- Groups

For more information, you can watch this extensive demo to explore the possibilities of Collibra for Desktop.



Installing Collibra for Desktop

This section describes how you can install and update Collibra for Desktop on macOS and Windows.

For the installation on Windows, you can download an installer from [Collibra Community](#) or you can install the app from the Microsoft Store. With the installer, you can also [execute remote installations](#).

For macOS, you can install the app with the Collibra installer. To apply the same configuration on all macOS installations in your network, you can also [preconfigure the app](#).

Install Collibra for Desktop on macOS	3
Install Collibra for Desktop on Windows	4
Updating Collibra for Desktop	6
Unattended app configuration on macOS	8
Unattended installation on Windows	9
Configuration file	12
Logging	13

Install Collibra for Desktop on macOS

Collibra for Desktop is available for [Windows](#) and macOS. This article describes how you can install the app on macOS.

System requirements

- You [have downloaded the installer file](#) Collibra for Desktop Setup-1.10.0.dmg.
- You have macOS 10.12 or newer.
- You have removed any older version of the app.

Note For a secure communication between Collibra for Desktop and your Collibra environment, you have to configure your environment to use a secure protocol, such as HTTPS.

Steps

1. Double-click Collibra for Desktop Setup-1.10.0.dmg.
2. In the installation window, drag and drop **Collibra for Desktop** into **Applications**.

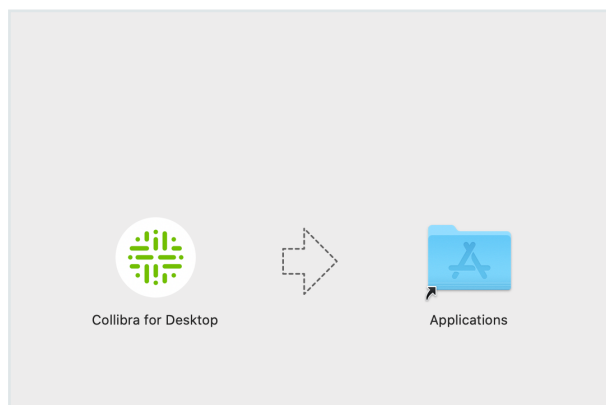

Note

If you see a security warning, click **Open**.



3. Add the application to the list of apps that are allowed to control your computer, via **System Preferences** → **Security & Privacy** → **Accessibility** and then the **Privacy** tab.

Note If you have used a 0.x version, you first have to remove the app from the Privacy settings and then add it again.

What's next?

You can now [start](#) Collibra for Desktop from the launchpad.

Tip

- When you start Collibra for Desktop, the app is added to the macOS status bar. This allows you to open the app even when you have closed the user interface.
- The [configuration](#) is saved in `/Users/<user>/Library/Application Support/Collibra for Desktop/config.json`.

Install Collibra for Desktop on Windows

Collibra for Desktop is available for Windows and [macOS](#). This article describes how you can install the app on Windows.

System requirements

- You have Windows 10 or newer.
- You [have downloaded the installer file](#) Collibra for Desktop Setup-1.10.0.exe or Collibra for Desktop Setup-non-admin-1.10.0.exe.
- You have administrator rights if you use the Collibra for Desktop Setup-1.10.0.exe installer.
- If you install Collibra for Desktop via the Microsoft Store or by using Collibra for Desktop Setup-non-admin-1.10.0.exe, you don't need the administrator rights.
- You have removed any older version of the app.

Note For a secure communication between Collibra for Desktop and your Collibra environment, you have to configure your environment to use HTTPS.

Microsoft Store

You can install Collibra for Desktop via the [Microsoft Store](#). Search for Collibra for Desktop and install it.

Install with administrator rights

1. Double-click **Collibra for Desktop Setup-1.10.0.exe** or execute the installer from the command line.
2. Optionally, accept to allow the installer to make changes on your operating system.
3. Enter the installation folder or use the default one.
4. Click **Install**.
5. Click **Finish**.

Install without administrator rights

If you don't have the permission to install software on your computer, but you still want to install and Collibra for Desktop, you can do so with the Collibra for Desktop Setup-non-admin-1.10.0.exe installer file.

1. Double-click Collibra for Desktop Setup-non-admin-1.10.0.exe or execute the installer from the command line.
2. Select to install only for the current user.
3. Click **Next**.
4. Select the installation folder.
The default installation folder for the current user is **C:\Users\.**
5. Click **Install**.
6. Click **Finish**.

What's next?

You can now [start](#) Collibra for Desktop via the Windows **Start** menu.

Tip

- When you start Collibra for Desktop, the app is added to the Windows system tray. This allows you to open the app even when you have closed the user interface.
- The installation directory is **C:\Program Files\Collibra for Desktop**.

Updating Collibra for Desktop

To update Collibra for Desktop, you have the following possibilities:

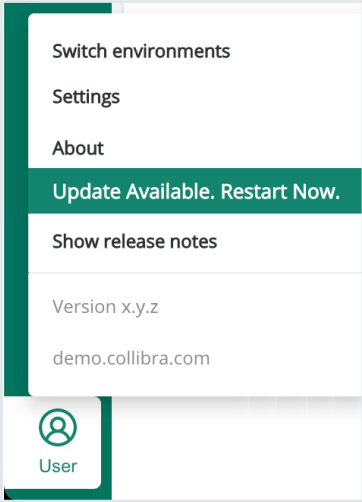
Update method	Description	Operating system
Auto-update	<p>The app automatically checks for new versions. The update is executed when you restart the app.</p>  <p>To enable this feature, you have to:</p> <ul style="list-style-type: none"> • Whitelist the S3 bucket collibra-otg-desktop-installers in the region eu-west-1. • Set the <code>DISABLE_AUTOUPDATES</code> (Windows) or <code>disableAutoUpdates</code> (macOS) to <i>false</i> in the configuration. 	macOS and Windows
Microsoft Store	<p>When you have installed the app via the Microsoft Store and the automatic updates of the store are enabled, the app will be updated when there is a new version available in the app store.</p>	Windows
Manual update	<p>Update the app manually by downloading a newer version of the installer and installing it over the existing version.</p> <p>To do so, you also have to disable the automatic updates by setting the <code>DISABLE_AUTOUPDATES</code> (Windows) or <code>disableAutoUpdates</code> (macOS) to <i>true</i> in the configuration.</p>	macOS and Windows

Unattended app configuration on macOS

You can configure Collibra for Desktop via the command line. This is considered an unattended configuration.

The advantage of an unattended configuration is that you can configure the software on remote systems with a predefined configuration.

Prerequisites

- You [have installed](#) Collibra for Desktop.
- You have administrative rights.

Steps

1. Open a terminal session.
2. Run the command: `/Applications/Collibra for Desktop.app/Contents/Resources/preconfig/config.sh` with the [configuration options](#) of your choice.
 - » The application is configured with the given options. Options that are not used keep their default values.

Installation options

To add an option, use the format `--<option> <value>`

Tip We recommend that you only configure the URL of your environment and configure all other options via Collibra Console of your environment.

macOS	Description	Example
<code>instance</code>	Set the URL of your Collibra Data Intelligence Cloud environment. Use double quotes around the URL.	<code>--instance "https://dgc.yourcompany.com"</code>
<code>sessionTimeout</code>	Set a timeout to automatically sign out users from Collibra for Desktop after a certain period of inactivity. The timeout is set in minutes. Without this setting, there is no timeout.	<code>--sessionTimeout 30</code>
<code>initialMessage</code>	Show a text message before the user signs in to Collibra for Desktop.	<code>--initialMessage "You may be viewing sensitive data."</code>

Example

```
/Applications/Collibra for
Desktop.app/Contents/Resources/preconfig/config.sh\
--instance https://dgc.yourcompany.com\
--sessionTimeout 30\
--initialMessage "You may be viewing sensitive data."
```

The used configurations are stored in the [Collibra for Desktop configuration file](#).

Unattended installation on Windows

You can install Collibra for Desktop with a couple of predefined options via the command line. This is considered an unattended installation.

The advantage of an unattended installation is that you can install the software on remote systems all with the same configuration.

Note You can only install Collibra for Desktop this way if there's no other version of the app installed on the PC.

Steps

This type of installation is typically managed by your company's mobile device management (MDM) software.

- For the installer Collibra for Desktop Setup-1.10.0.exe, the MDM user who installs the application needs administrator rights. The application will be available to all users. Automatic updates will only take place for users who have administrator rights.
- For the installer Collibra for Desktop Setup-non-admin-1.10.0.exe, the MDM user who installs the application does not need administrator rights. The application will only be available to the user who is at that moment signed in to Windows. Automatic updates will always take place whether that Windows user has administrator rights or not.

Run the installer with the argument /s. The application is installed with a default configuration. To customize the installation, you can add options after the /s argument.

```
Collibra for Desktop Setup-1.10.0.exe /S
```

```
Collibra for Desktop Setup-non-admin-1.10.0.exe /S
```

Installation options

You can run the command with options. The format to add an option is –
<option>=<value>.

Note Make sure that you add the options after the /s.

Tip We recommend that you only configure the URL of your environment and configure all other options via Collibra Console of your environment.

Windows	Description	Example
- INSTANCE	Set the URL of your Collibra Data Intelligence Cloud environment. Use double quotes around the URL.	- INSTANCE="https://dgc.yourcompany.com"
- SESSION_ TIMEOUT	Set a timeout to automatically sign out users from Collibra for Desktop after a certain period of inactivity. The timeout is set in minutes. Without this setting, there is no timeout.	-SESSION_TIMEOUT=30
- INITIAL_ MESSAGE	Show a text message before the user signs in to Collibra for Desktop.	-INITIAL_MESSAGE="You may be viewing sensitive data."

Example

```
"Collibra for Desktop Setup-non-admin-1.10.0.exe" /S\
-INSTANCE="https://dgc.yourcompany.com"
-SESSION_TIMEOUT=30\
-INITIAL_MESSAGE="You may be viewing sensitive data."
```

or

```
"Collibra for Desktop Setup-1.10.0.exe" /S\
-INSTANCE="https://dgc.yourcompany.com"
-SESSION_TIMEOUT=30\
-INITIAL_MESSAGE="You may be viewing sensitive data."
```

The used configurations are stored in the [Collibra for Desktop configuration file](#).

Configuration file

The Collibra for Desktop configuration file is in JSON format, on macOS as well as Windows.

You can find the configuration file in the following directory:

Operating System	Location
macOS	~/Library/Application Support/Collibra for Desktop/config.json
Windows	C:\Program Files\Collibra for Desktop\config.json

Example

```
{
  "shortcut": "Shift+Alt+Command+K",
  "instance": "https://dgc.yourcompany.com",
  "configurable": false,
  "disableShortcut": true,
  "disableAutoUpdates": false,
  "dgcName": "my environment",
```

```

    "defaultFilterId": "921b9474-1373-45ea-95fa-
d966268f32c1",
    "personalFilterId": "bbd96b18-f7aa-4d37-a50d-
7e2caa48ef59"
  }

```

Logging

In case you have authentication issues in Collibra for Desktop, you can enable logging.

You can find the log files in the following location:

Operating System	Location
macOS	~/Library/Logs/Collibra for Desktop/log.log
Windows	%USERPROFILE%\AppData\Roaming\Collibra for Desktop\logs\log.log

To enable the logging, you have to add the following line to the Collibra for Desktop configuration file:

```
"logCookiesAndTokens": true
```

For example:

```

{
  "shortcut": "Shift+Alt+Command+K",
  "instance": "https://dgc.yourcompany.com",
  "configurable": false,
  "disableShortcut": true,
  "disableAutoUpdates": false,
  "dgcName": "my environment",
  "defaultFilterId": "921b9474-1373-45ea-95fa-
d966268f32c1",
  "personalFilterId": "bbd96b18-f7aa-4d37-a50d-
7e2caa48ef59",

```

```
"logCookiesAndTokens":true
```



Sign in to Collibra for Desktop

Signing in to the Collibra for Desktop uses the same authentication mechanism as your Collibra Data Intelligence Cloud environment. Keep in mind that it is not possible to automatically sign in to the app, even in [automatic startup of the app](#) is enabled.

1. Open Collibra for Desktop.

Note If a security message is shown, click **Open**.

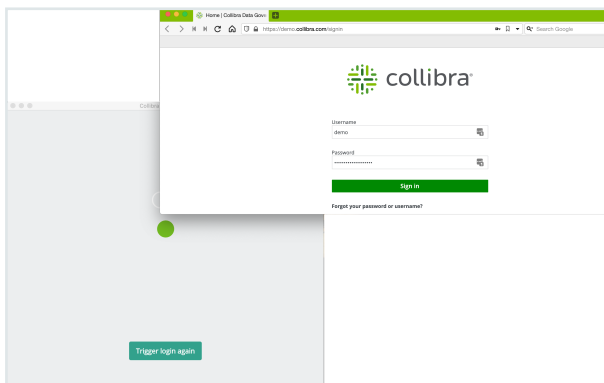
2. In the **URL** field, enter the address of the Collibra Data Intelligence Cloud environment to which you want to connect.
3. Click **NEXT**.



- » The sign-in page appears in your default web browser.

Tip If you accidentally closed the sign-in page in your web browser, click **Trigger login again** to open the page again.

4. Enter your Collibra credentials.

Tip If authentication for your environment is set up with an SSO system, then enter your SSO credentials.

5. Click **Open Collibra for Desktop**.

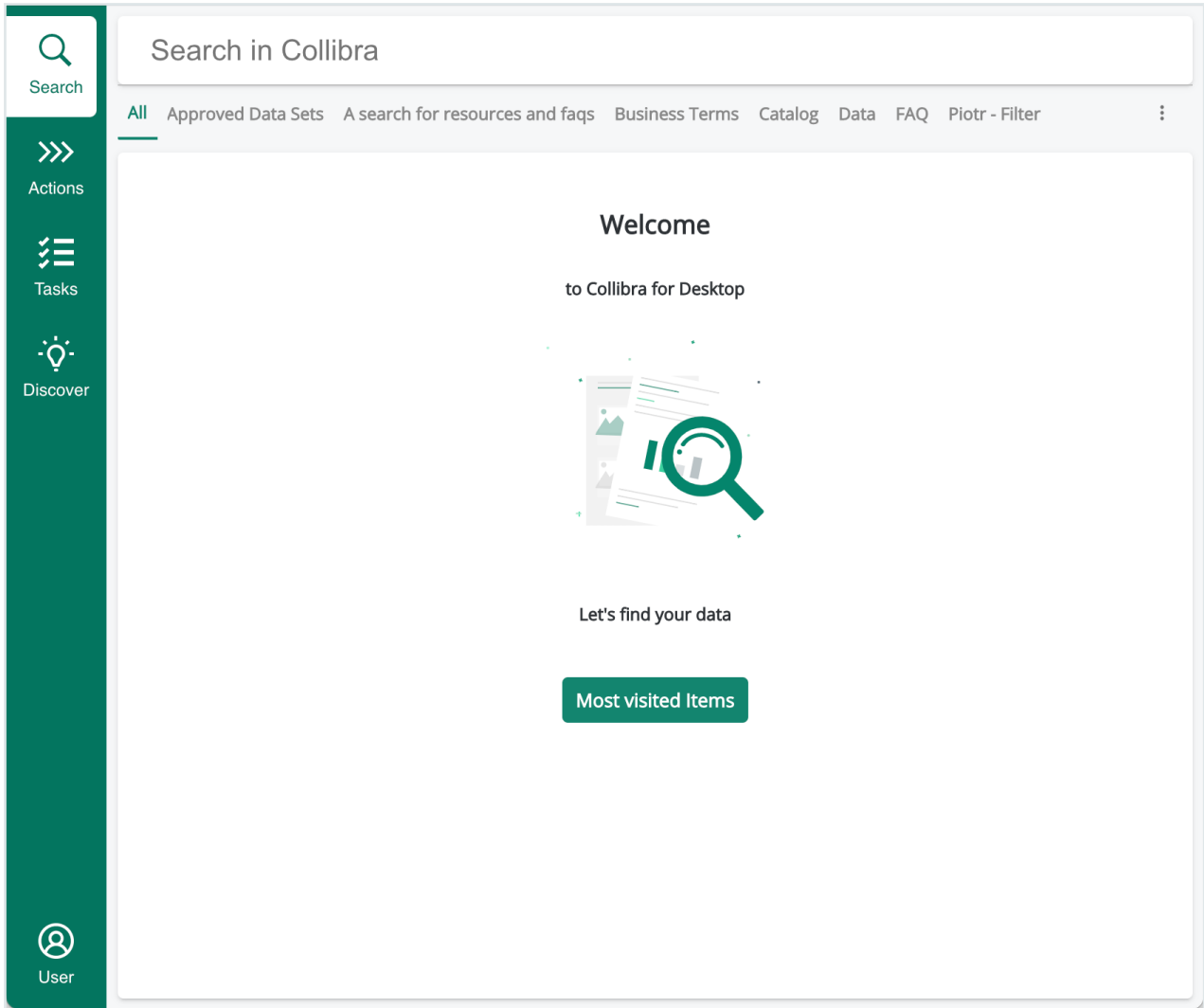

Tip After a period of inactivity, you are automatically signed out. Signing back in only requires your credentials and not the environment's URL.

Switch environments

If your organization has more than one Collibra environment, you can switch between those environments.

1. In the navigation bar, click .
2. Click **Switch environments**.
 - » You return to the sign-in page.
3. Enter a URL of another Collibra environment, or select one from the drop-down list.

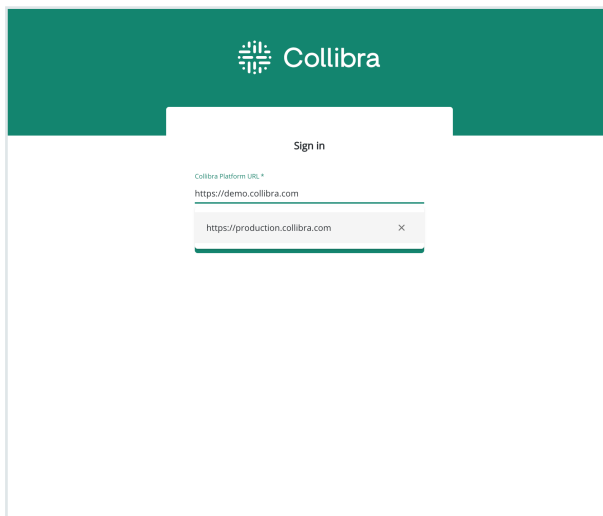

4. Click **Next**.
 - » You are redirected to the sign-in page of the selected environment in your default web browser.
5. Enter your credentials.
 - You are redirected to Collibra for Desktop.

You can delete environments from the drop-down list by clicking  next to the environment in the list.

Collibra for Desktop user interface

In this section, we will make you familiar with the user interface of Collibra for Desktop.

User interface	21
Asset details	22
Community assets	24
Domain assets	25
Table assets	27
Column assets	28





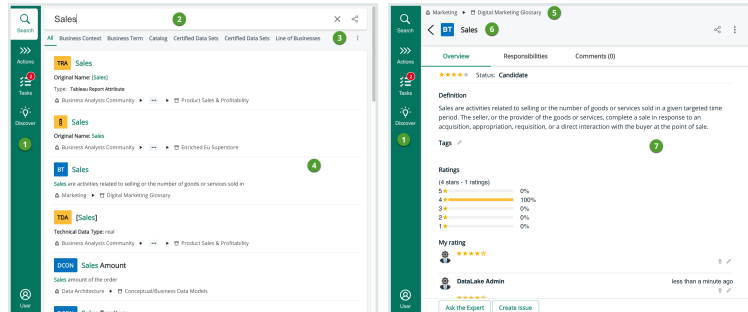

User interface

The Collibra for Desktop user interface contains the following elements:



Item	Description
<p>1</p>	<p>The navigation bar of the app to navigate between the different sections in the app, for example the search application and tasks.</p> <ul style="list-style-type: none"> • Search: Start searching for data in your environment. • Actions: The list of workflows that you can start. This list is defined in Collibra Console of your environment. • Tasks: The list of tasks that are assigned to you. • Discover: The list of recommended, last updated and most visited assets.
<p>2</p>	<p>The search field to enter your search query.</p> <p>The  icon on the right-hand side allows you to share your search query.</p>

Item	Description
3	<p>The available filters that you can apply on your search results.</p> <ul style="list-style-type: none"> • All: Clear all filters • If you have set a default filter, it is marked with . • If the Administrator has set a default filter, it is marked with .
4	The search results of your search query.
5	The asset's breadcrumbs to see where the asset is stored.
6	<p>The title bar of asset page. It contains the asset type, the asset name and the asset actions.</p> <ul style="list-style-type: none"> • Share the asset () • Export to PDF () • Open the asset in Collibra Data Intelligence Cloud () <p>Click the asset name to open the asset in Collibra Data Intelligence Cloud.</p>
7	<p>The details of the selected asset divided over the tabs Overview, Responsibilities, Comments and optionally Summary.</p> <p>For more information, see Asset details.</p>

Asset details

The details of an asset are shown on the tabs **Overview**, **Responsibilities** and **Comments**. Some assets such as Tables, Columns and Tableau Dashboards also have a **Summary** tab.

If an asset has a diagram picture, you also see a **Diagrams** tab.

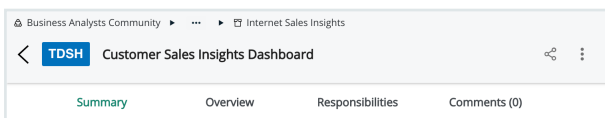

Tab	Description
Overview	<p>The Overview tab gives an overview of the asset, its status and characteristics. Also, all relations and complex relations are shown on this tab no matter the amount of relations.</p> <ul style="list-style-type: none"> • If you click a related asset on the Overview tab, the details of the related asset are shown. • If you click a tag, the search engine automatically returns all the data that have the selected tag. • If you follow a link to another asset in your Collibra environment, for example in the description of the asset, the linked asset is opened in the app. All other links are opened in your web browser.
Responsibilities	<p>The Responsibilities tab gives an overview of the roles and their respective users that are assigned to the asset.</p> <p>Via this tab, you can send an email to the assigned users. Sending an email goes through your default email application.</p> <p>If a user group is in this overview, you can click this group to see the members of this group.</p>
Diagrams	<p>The Diagrams tab gives an overview of diagram pictures. These diagram pictures allow a better understanding of the asset's context. You will also have a direct link to open the corresponding diagram in Collibra.</p>
Comments	<p>The Comments tab shows all comments and allows you to add a comment.</p>
Summary	<p>The Summary tab is only available for Table assets and Dashboard assets.</p> <ul style="list-style-type: none"> • Table asset: It shows specific Table data, such as an abstract of the table, lineage and its related data sets and columns. You can sort these columns by name and data type. • Dashboard asset: It shows a summary of a dashboard asset, whether it's a Tableau Dashboard or a Power BI dashboard.

Hyperlinks

On the **Overview** and **Summary** tab, you can find text attributes, for example the description of the asset. Text attributes can contain hyperlinks to external websites or to other assets in the Collibra environment.

It is possible that an asset is [automatically converted to a hyperlink](#). It may occur that assets with identical names exist in different domains. In that situation, you will see a popup window with all the corresponding assets if you click such a link.

Community assets

A community is a grouping of other communities and domains. It often corresponds to functional divisions in a company and works best if it is aligned with the company's governance organization.. When you open a community asset, you see the **Overview** tab with basic information about the community.

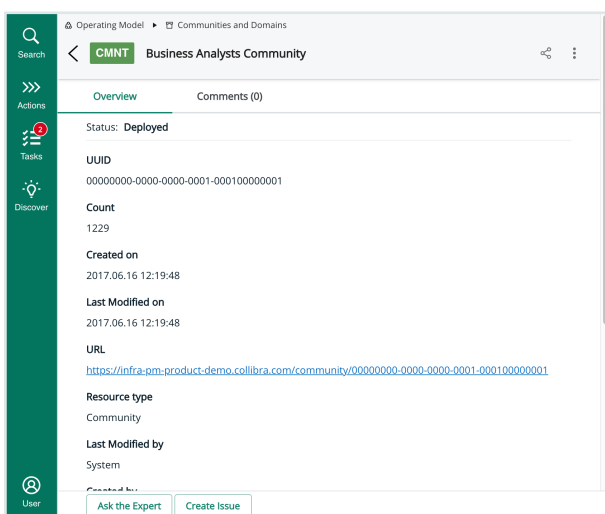

Overview tab

Property	Description
Status	The status of the community.
UUID	The unique identifier of the community in your Collibra environment.

Property	Description
Count	The number of assets in the community.
Created on / Last Modified on	Respectively the creation date and the last modification date of the community.
URL	The direct link to the community page in your Collibra environment.
Resource type	The resource type of the community.
Created by / Last Modified by	Respectively the username that created and last modified the community.
System Resource	The indication of the community is a system community or not.
contains Domain	The domains that belong to this community.
sub-community	The subcommunities that belong to this community.
parent Community	The name of the community which the community belongs to. This is only applicable for subcommunities.
Workflow Assignment Rule	The workflows that apply to this community..
Tags	The tags that have been added to the community.

Domain assets

When you open domain assets in Collibra for Desktop, you can see the main properties of the domain such as number of assets, status and domain type.

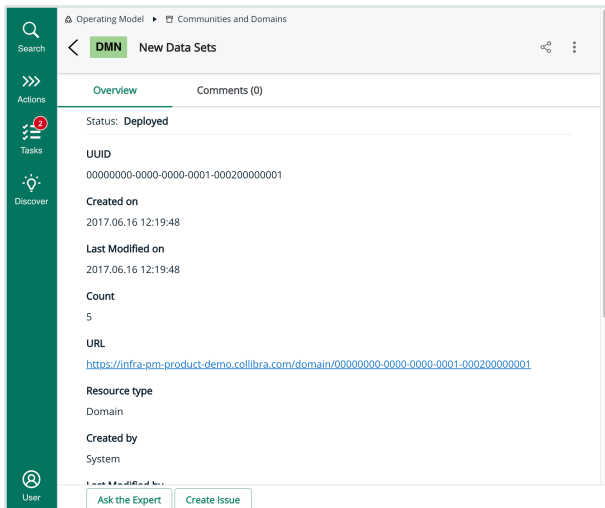

Overview tab

Property	Description
Status	The status of the domain.
UUID	The unique identifier of the domain in your Colibra environment.
Created on / Last Modified on	Respectively the creation date and the last modification date of the domain.
Count	The number of assets in the domain.
URL	The direct link to the domain page in your Colibra environment.
Resource type	The resource type of the domain.
Created by / Last Modified by	Respectively the username that created and last modified the domain.
System Resource	The indication of the domain is a system domain or not.
belongs to Community	The name of the community to which the domain belongs.
is of type Domain Type	The domain type.
Tags	The tags that have been added to the domain.

Table assets

When you open a Table asset in Collibra for Desktop, a Summary tab is shown, which gives you a comprehensive overview of the table's properties.

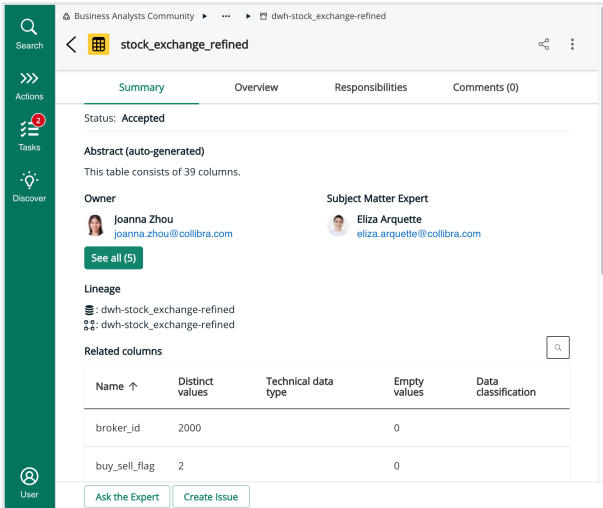

Abstract

The auto-generated abstract provides the details of the table, such as the number of columns and possible classifications of columns. If you click a classification, the table in the **Related columns** section is filtered by the selected classification. You can click multiple classifications to reduce the number of rows in the table.

The abstract also shows the users that have responsibilities on this asset. Click **See all** to go to the **Responsibilities** tab of the asset.

In the Lineage section of the abstract, you can see to which source the table belongs. In the above example, the table belongs to the schema **dwh-stock_exchange-refined**, which is part of the database **dwh-stock_exchange-refined**. If you click any of the lineage assets, you open the respective asset page. Click **<** to return to the previous page.

Related columns

The table in the **Related columns** section shows all table columns, which are paginated per 10, by default. If you click a classification in the abstract, the corresponding column is shown in the

table and highlighted as a filter, above the table.

Use the search field to search for any column name. The table is dynamically updated as you type.

You can also sort the table by column name.

Column assets

When you open a Column asset page in Collibra for Desktop, a Summary tab is shown, which gives you a comprehensive overview of the column's properties.

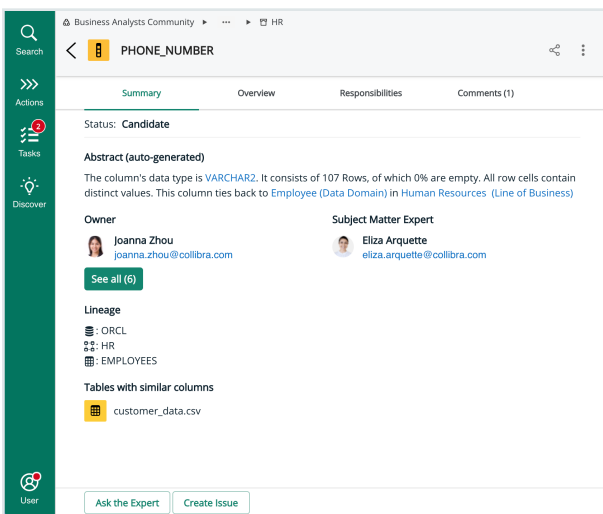

Abstract

The auto-generated abstract provides the following details of the column if available:

- Primary key: the column is the primary key of the table. When you click the table name, you open the table summary.
- Data type: the data type of the column.
- Number of rows: the number of rows and percentage of empty rows.
- Number of distinct values: the number of distinct values.
- Classification: the classification of the column. When you click the classification, you open the summary of the table to which it belongs.
- Data Domain and Line of Business: reference to the data domain and line of business to which the column belongs.

Responsibilities

This section shows the users that have responsibilities on this asset. Click **See all** to go to the **Responsibilities** tab of the asset.

Lineage

This section shows links to the lineage of the column. Here, you can see to which source the column belongs.

In the above example, the column belongs to the table **EMPLOYEES**, which is part of the schema **HR**, which is part of the database **ORCL**. If you click any of the assets in this section, you open the respective asset page. Click < to return to the previous page.

Related datasets

This section shows a list of data sets in which the column appears.

Similar Tables

This section shows a list of tables, other than the one to which the column belongs, that also have a column with the same name.

Searching with Collibra for Desktop

You can use Collibra for Desktop to quickly [search](#) in your Collibra Data Intelligence Cloud environment. You can search for specific assets, communities, domains, users, user groups and more.

About Collibra for Desktop Search	30
Discover	34
Search for assets	36
Filtering search results	37
Wildcards and symbols for searching	39
Share search queries	40

About Collibra for Desktop Search

You can use Collibra for Desktop to quickly [search](#) in your Collibra Data Intelligence Cloud environment.

Recently searches and visited assets

When you start the app, you have an overview of your last search queries and your recently visited assets.



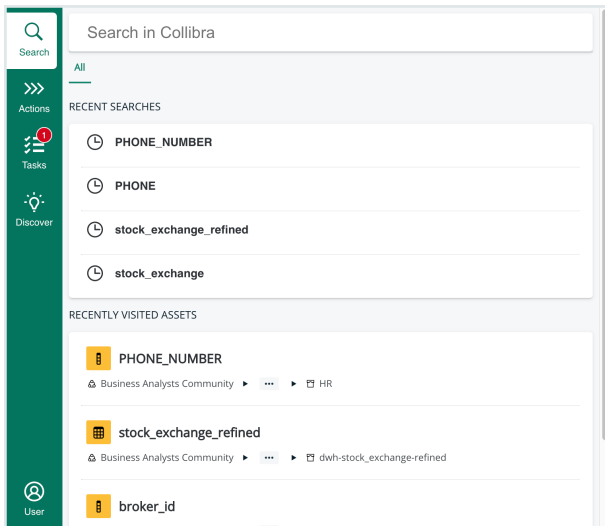

If you click a recent search query, you will execute the search again.

If you click a recently visited asset, you open the asset page.

Smart filter suggestions

For a more intuitive search experience, you can add some specific filter words to your search query:

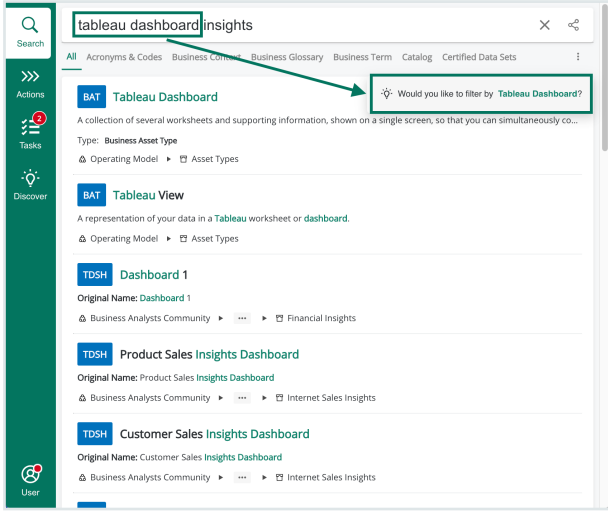
Filter words	Example
<p>an asset type + search query</p>	<p>tableau dashboard insights</p>  <p>If you misspell an asset type, the search can still suggest the filter with the correct spelling. Also, synonyms of asset types are taken into account.</p> <div style="background-color: #e0e0e0; padding: 10px; border: 1px solid #ccc;"> <p>Example</p> <ul style="list-style-type: none"> • If you enter "Tableua" instead of "Tableau", the search will still suggest the filter with the correct spelling. • If you search for "report", the search suggests "Tableau Dashboard". </div>

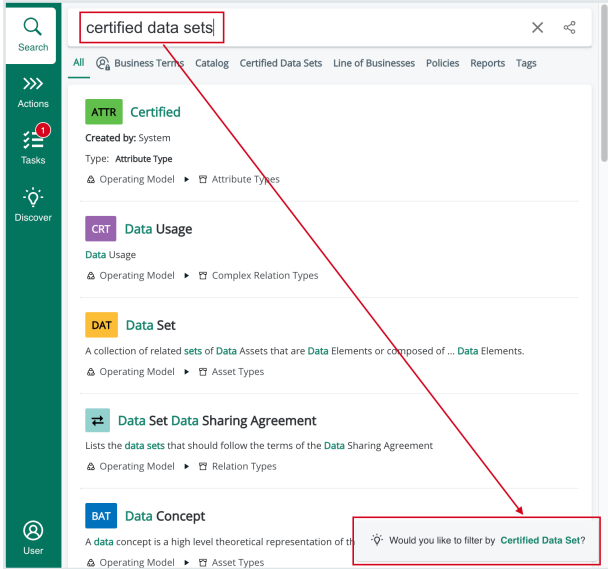
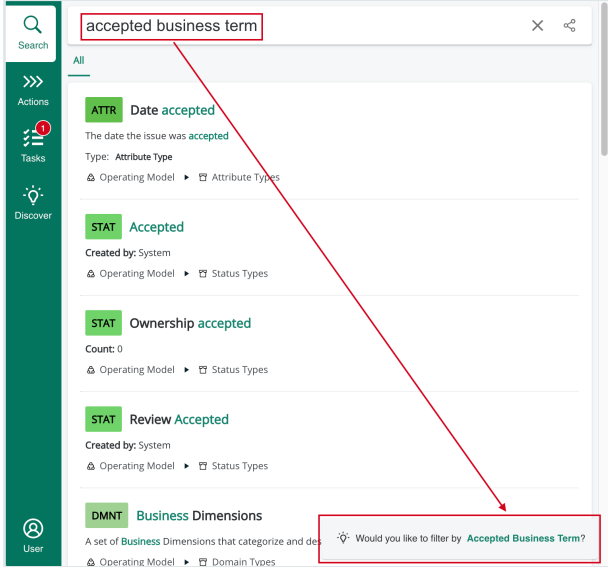
Filter words	Example
<p>"certified" + search query</p>	<p>certified data sets</p> 
<p>an asset status + search query</p>	<p>accepted business term</p> 

As shown in the examples, you can also combine filter words.

If you add the keyword "recent" to your search query, the search results will be ordered by creation date in descending order.

Discover

The **Discover** section of the navigation bar includes:

- A list of the most viewed assets in your environment in the **Most Visited Assets** tab.
- A list of the last updated assets in your environment in the **Last Updated** tab.
- A list of assets that may be of interest to you in the **Recommendations** tab.

This section is only shown if a list of most visited assets exists.

Most Visited Assets

The assets that appear under the **Most Visited Assets** tab are the ones that users have visited the most in the Collibra Data Intelligence Cloud environment.

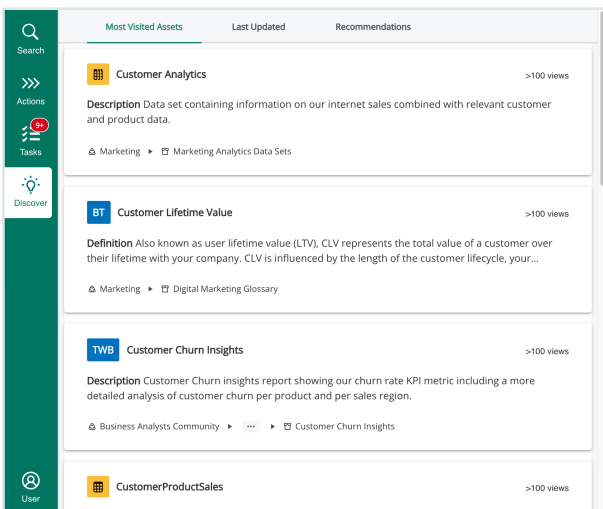

Last Updated

The assets that appear under the **Last Updated** tab are the ones that have been updated most recently in your Collibra environment.

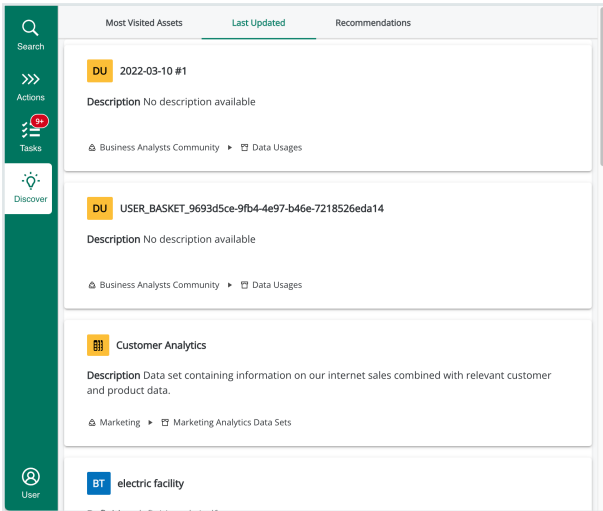

Recommendations

The assets that appear under the **Recommendations** tab are selected through artificial intelligence and are based on assets that you have visited, on certain relation types and on the past actions of similar users. The filters that you see on this tab, are also based on the browsing history in the app.

The **See more** button retrieves up to 12 more recommendations.

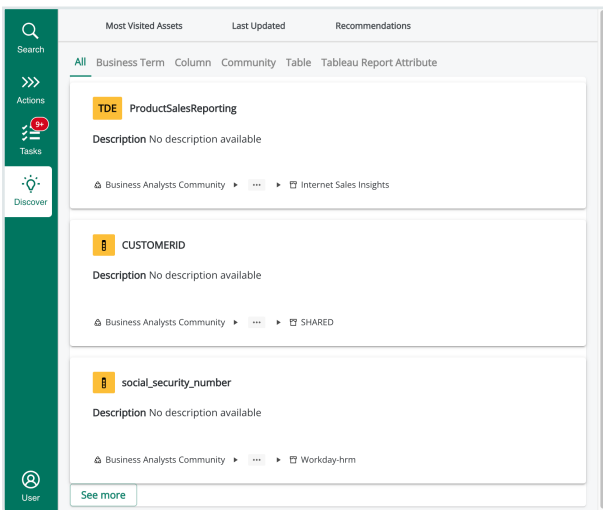

Search for assets

There are several ways to search for assets in Collibra Data Intelligence Cloud.

Search via the keyboard shortcut

In any application, select the text you want to search for and then press the keyboard shortcut.

The selected text is copied to the app and the search query is executed.

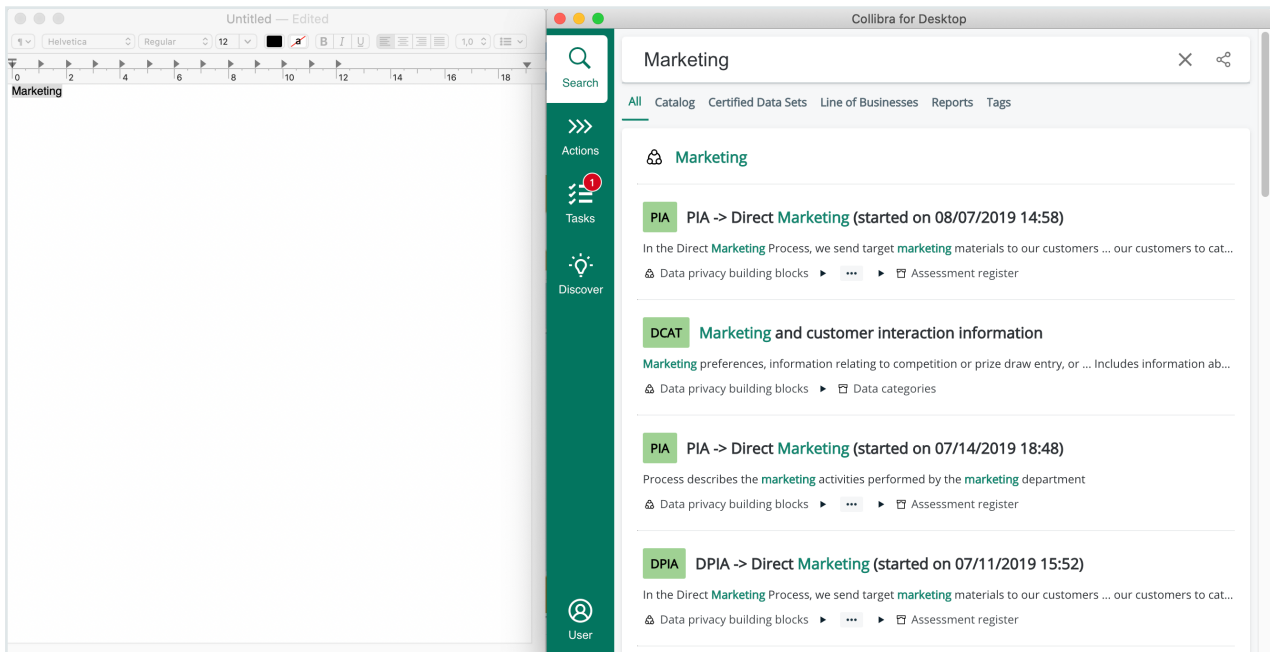

Note The breadcrumbs in the search results are only available if you are connected to a Collibra 5.7 environment or newer.

Search via the application

Enter the text you want to search for in the **Search in Collibra** field. As you type, suggestions appear.

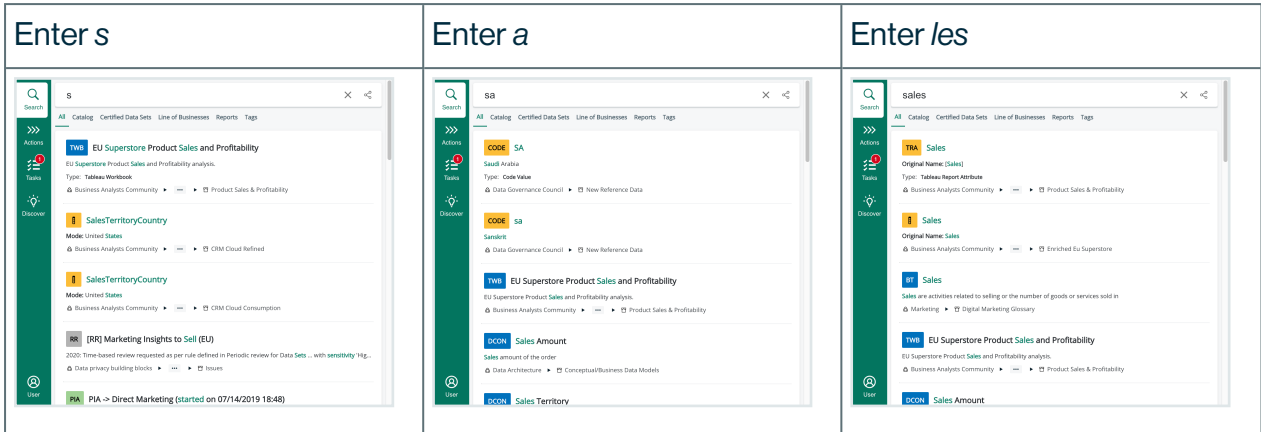

Tip

- You can use [wildcards](#) to aid your search.
- If you enter a unique asset ID or paste a shared asset link, the corresponding asset page opens immediately.

Filtering search results

When searching for data, the number of results can be huge and it can be difficult to find what you're looking for.

To find your data more easily, you can apply filters to the search results. The filters are taken from your Collibra Data Intelligence Cloud environment. Only the filters that you created and those that were shared with you are available to you.

To show more or fewer filters, you have to [add](#) or [delete](#) them in your Collibra environment.

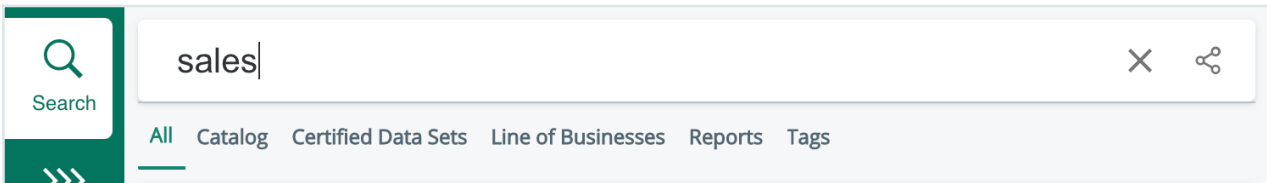

When you apply a filter, the selected filter is highlighted.

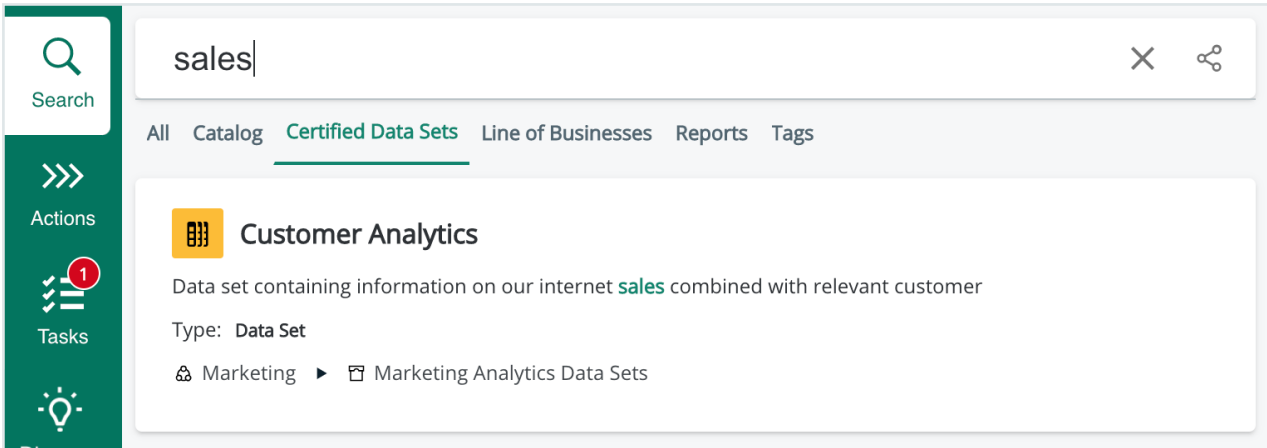

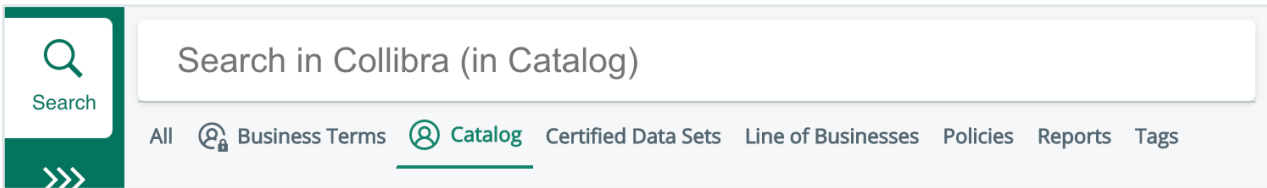

Default filters

You can also [select a default filter](#) that will be applied for every search query. When you have selected a default filter, the filter is shown in the search field of the application and on the search results page.

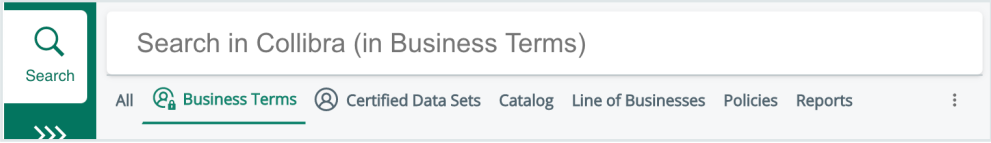

There are two possible default filters:

Default filter	Description
Defined by administrator	<p>This filter is defined by your system administrator, who set this filter during the installation using a preconfiguration.</p> <p>On the search results page, this filter is marked by .</p>  <p>The screenshot shows the search bar with the text 'Search in Collibra (in Business Terms)'. The navigation tabs are 'All', 'Business Terms' (highlighted), 'Certified Data Sets', 'Catalog', 'Line of Businesses', 'Policies', and 'Reports'. The left-side menu shows 'Search' and 'Actions'.</p>

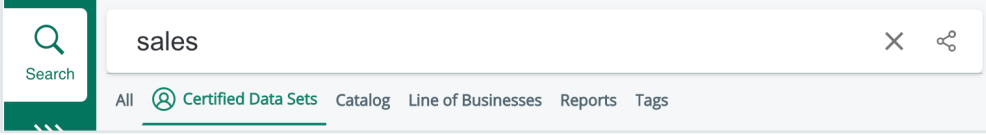
Default filter	Description
Defined by user	<p>This filter is defined by the user in the app's settings.</p> <p>On the search results page, this filter is marked by .</p>  <p>If you select a filter in the app's settings, it will overrule any filter that might have been defined by your administrator. If you then set the filter to None, the search filter that was defined by your administrator will be enabled again.</p>

Wildcards and symbols for searching

If you want to find a resource, but are not quite sure of its name, you can use the following wildcards:

Wildcard	Description
?	<p>Replaces any single character.</p> <p>Example: by typing <i>?owie</i>, you can find Bowie, Rowie, Mowie, and so on.</p>
*	<p>Replaces any string of characters.</p> <p>Example: by typing <i>B*e</i>, you can find Bowie, Badge, Byte, and so on.</p>
~	<p>Represents a fuzzy search, words with spelling similar to the search query.</p> <p>Example: by typing <i>Owi~</i>, you can find Ozi, Zowie, Bowie, and so on.</p>
!	<p>Excludes words.</p> <p>Example: by typing <i>!David Bowie</i>, you can find Lester Bowie, Joe Bowie and so on.</p>
" "	<p>Represents a literal search.</p> <p>Example: by typing <i>"David Bowie"</i>, you can find David Bowie and David Bowie Songs, but not David or Bowie.</p>

Share search queries

When you search for an asset, not only can you [share a link to an asset with another user](#), you can also share a link to your search query. If you applied a filter to your search query, the applied filter is also included in the link.

As is true when sharing a link to an asset, the link can have the normal URL format (https://) to open with your web browser or the Collibra for Desktop specific format (otg://) to open with the Collibra for Desktop app.

Steps

1. Enter a search query.
2. Optionally, select a filter.
3. In the search field to the right, click .
4. In the **Share** dialog box, click **Copy** next to the share link.

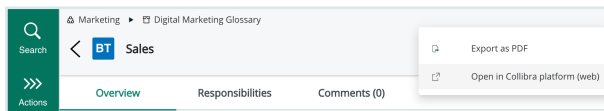

5. Send the link to the user with whom you want to share the search query.

Working with assets

With Collibra for Desktop you can quickly look up data in Collibra Data Intelligence Cloud from any application, for example your favorite text editor, a web browser or mail application.

In this chapter

Working with tags	43
Export to PDF	44
Open an asset in Collibra Data Intelligence Cloud	44
Diagram pictures	45
Share an asset	46
Open a shared link	47



Working with tags

You can add and delete tags on an asset page in the app. You don't have to navigate to your Collibra Data Intelligence Cloud environment to do so.

Add tags

1. [Search](#) for an asset.
2. Open the details of the asset.
3. On the **Overview** tab in the **Tags** section, click .

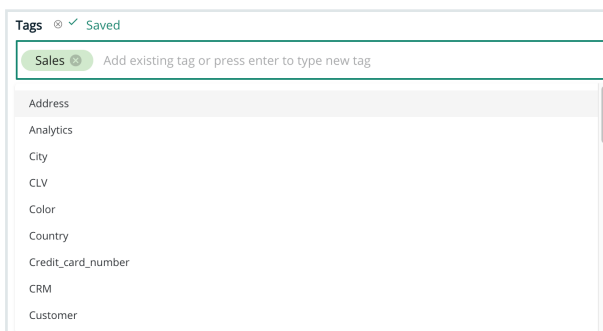

4. Enter a new tag and press `Enter`.
 - » The tag is automatically saved.

Tip

- As you type, already existing tags that match what you are typing are suggested. If you want to use a suggested tag, you can click on it. Otherwise, you can ignore the suggestions.
- You can add as many tags as you want.

5. Click  to close the tag editor.

Delete tags

1. [Search](#) for an asset.
2. Open the details of the asset.
3. On the **Overview** tab, click .

4. Click  next to the tag that you want to delete.
 - » The tag list is automatically saved.

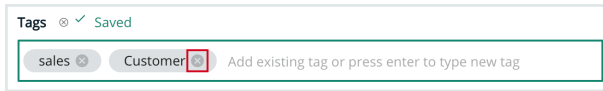



5. Click  to close the tag editor.

Export to PDF

You can [share an asset](#) with somebody by sending a link, but you can also export the asset to PDF. The PDF contains the content of the **Overview** tab of the asset page except the ratings.

The default name of the PDF file will be the asset name but you give it any name.

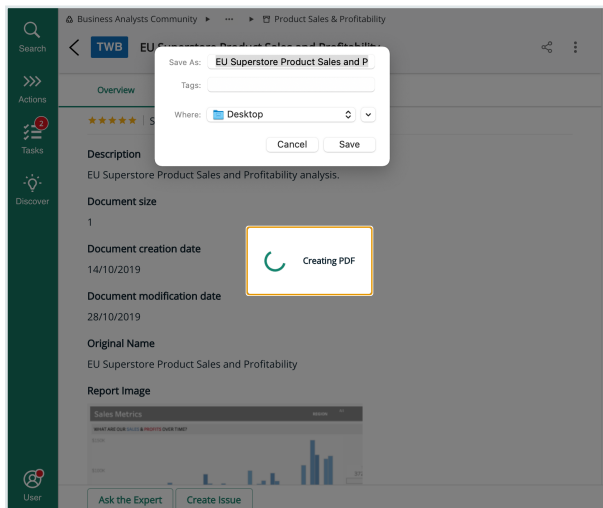

Steps

1. [Search](#) for an asset.
2. On the search results page, click the asset you want to export.
3. In the header of the page, click  and then  **Export to PDF**.
4. Save the asset page as PDF.



Open an asset in Collibra Data Intelligence Cloud

You can open any asset in Collibra, directly from Collibra for Desktop.

1. Search for an asset.
2. On the search results page, click the asset you want to open in Collibra.
3. In the header of the page, click  and then  **Open in Collibra platform (web)**.

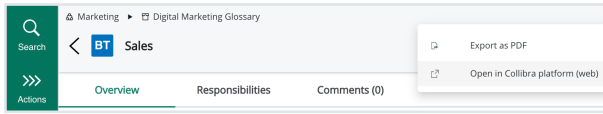
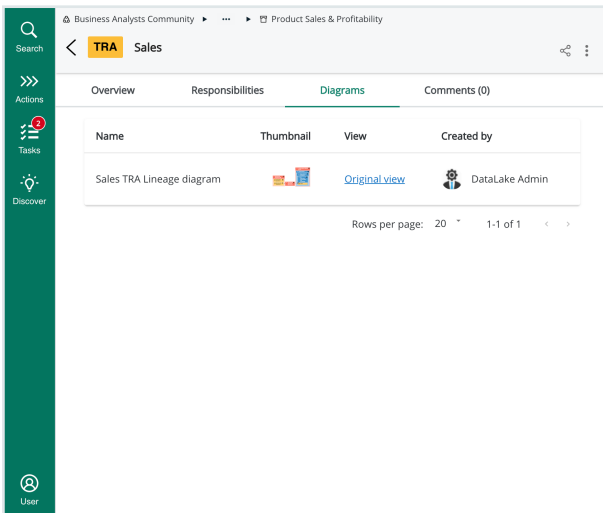

Diagram pictures

When you or another user create a diagram picture of an asset in your Collibra Data Intelligence Cloud environment, you can also open the picture in the Collibra for Desktop app.

When you open an asset that has pictures, you see the **Diagrams** tab.



This tab contains an overview of all diagram pictures that are created for this asset. For each picture, the following information is provided:

Picture element	Description
Name	The name of the picture as given by the creator of the diagram picture.
Thumbnail	The thumbnail gives you an impression of the picture. Click the thumbnail to see the picture in a larger format.

Picture element	Description
View	<p>A link to the diagram in the Collibra environment.</p> <p>This is useful if the picture is so large that you have to scroll a lot. The web interface provides more tools for navigating in the diagram.</p>
Created by	<p>The user who created the diagram picture.</p> <p>This allows you to contact the creator if you have questions about the diagram.</p>

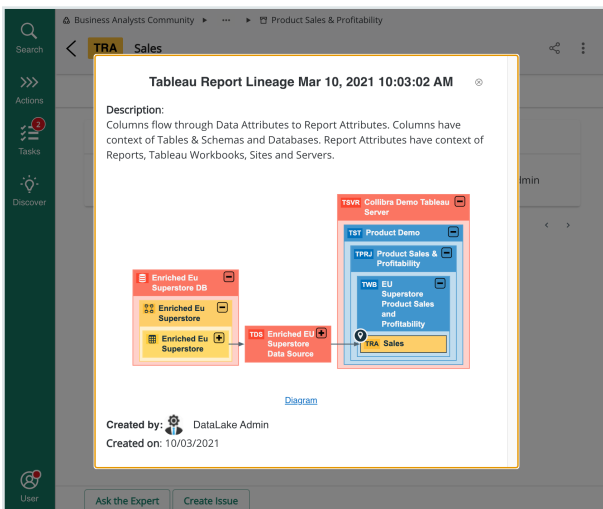

Share an asset

If you want to share an asset with someone, you can retrieve the link to the asset and send it to another person. The link can be opened in your web browser or in Collibra for Desktop.

Steps

1. [Search](#) for an asset.
2. On the search results page, click the asset you want to share.
3. In the header of the page, click .

4. In the **Share** dialog box, click **Copy** next to the share link.

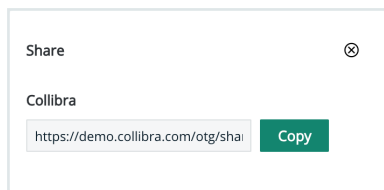

5. Send the link to the user with whom you want to share the asset.

You can also use this link to use in your documents, for example in Word or PDF. Following such a link will then give you the option to open the web interface or Collibra for Desktop.

Open a shared link

If you receive a shared link from somebody, whether it's a link to an asset or a search query, you can open it in your Collibra environment or in Collibra for Desktop.

Copy the received link and paste it in your browser to open the asset or the search query.

If your environment is version 2020.10 or newer and you have Collibra for Desktop installed, your web browser will give you the option to open the asset or search query in Collibra for Desktop or your browser.

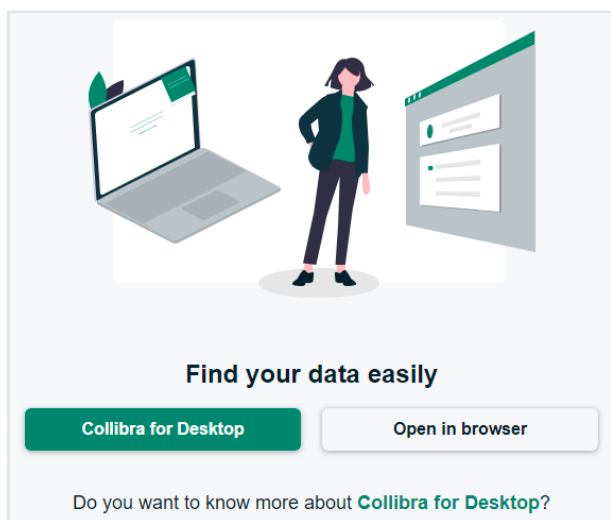

Tip In a 5.7.6 or older environment, the received link can have the URL format (https://) or a Collibra for Desktop specific format (otg://). To open a Collibra for Desktop specific format link, paste it in your web browser, which will then suggest opening the link with Collibra for Desktop.

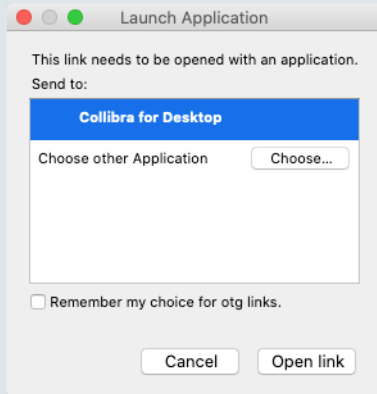

Working with comments

When you open an asset page, you can add, edit and delete comments in the app, you don't have to navigate to your Colibra Data Intelligence Cloud environment to do so.

Add a comment

1. [Search](#) for an asset.
2. Open the details of the asset.
3. Go to the **Comments** tab.
4. Enter your comment.

Tip In your comments, you can apply [basic text formatting](#) or insert images.

5. Click **Save**.

Edit a comment

1. [Search](#) for an asset.
2. Open the details of the asset.
3. Go to the **Comments** tab.
4. Click  next to the comment that you want to update.

Tip You can only edit your own comments.

5. Update the comment.
6. Click **Save**.



Delete a comment

1. [Search](#) for an asset.
2. Open the details of the asset.
3. Go to the **Comments** tab.
4. Click  next to the comment that you want to delete.

Tip You can only delete your own comments.

5. Click **Delete** for confirmation.

Comments formatting options

Formatting option	Description
B	Apply the bold style to the selected text.
<i>I</i>	Apply the italics style to the selected text.
<u>U</u>	Apply the underline style to the selected text.
S	Apply the strikethrough style to the selected text.
☰	Add a bulleted list.
☰	Add a numbered list.
☰	Add a task list.
	Insert an image in your comment.
<i>I</i> _x	Clear the formatting of a text selection.

Working with workflows

A workflow in Collibra Data Intelligence Cloud is an automated series of actions that produces a specified outcome. In the progression of a workflow, Collibra users may be required to complete tasks.

Workflows are essential for collaborating on assets and automating processes.

In Collibra for Desktop, you can start workflows and complete tasks that are assigned to you. Note that Collibra for Desktop retrieves all workflow information from the Collibra environment and that it as such respects roles, permissions, asset types, ... as defined in Collibra.

This section covers how to work with workflows and tasks.

Starting workflows	55
Working with tasks	57
Reassign a task	59
Cancel a task	60



Starting workflows

In Collibra for Desktop, there are several ways to start a workflow.

Starting workflows from the navigation bar

The following image shows the designated **Actions** section in the navigation bar. Hover over a workflow to see a short description of the workflow.

Note The list of workflows that are available in the **Actions** section, is defined in [Collibra Console](#).

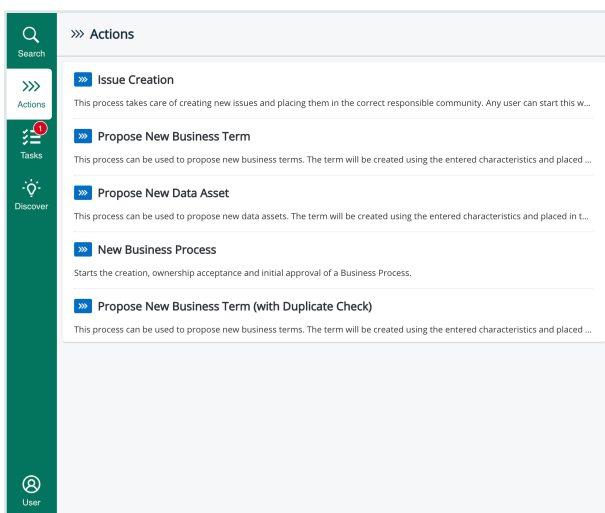

If you click a workflow to initiate it, a sidebar expands from the right side of the app.

Fill out the necessary fields to proceed with the workflow.

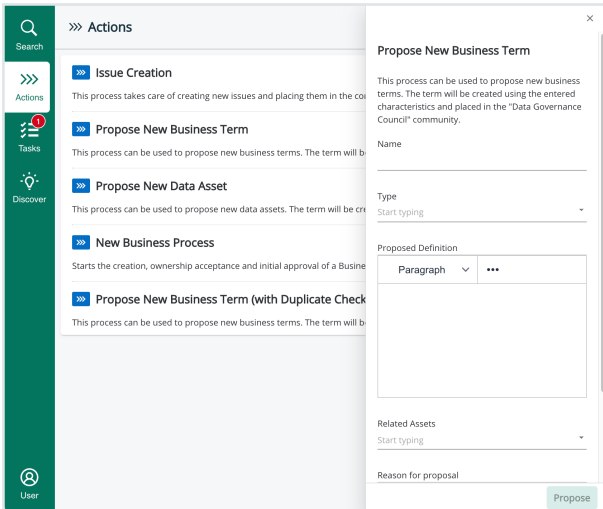

Starting actions from an asset page

The following image shows the action buttons on an asset page. You can find action buttons on the **Overview** and **Responsibilities** tabs.

Note The list of workflows that are available on an asset page, is defined in [Collibra Console](#).

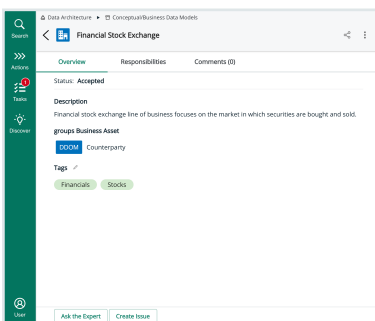

When you click an action button, a sidebar expands from the right side of the app.

Fill out the necessary fields to proceed with the workflow.

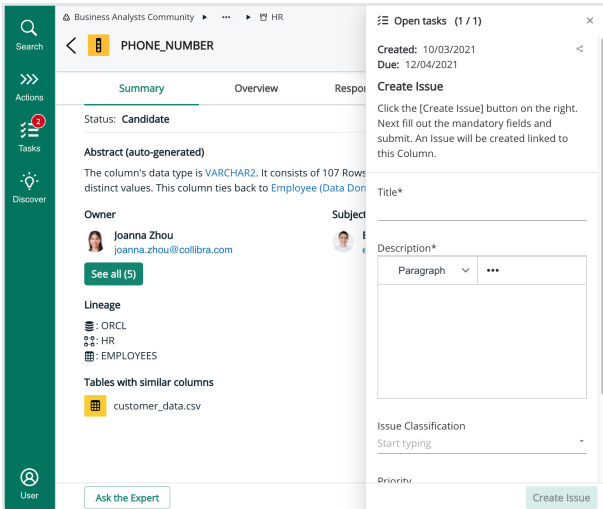

Working with tasks

In the progression of a workflow, Colibra users may be required to complete tasks. As a user, you can complete these tasks via Colibra Data Intelligence Cloud or Colibra for Desktop.

All tasks that are assigned to you are shown in the Tasks section in the navigation bar.

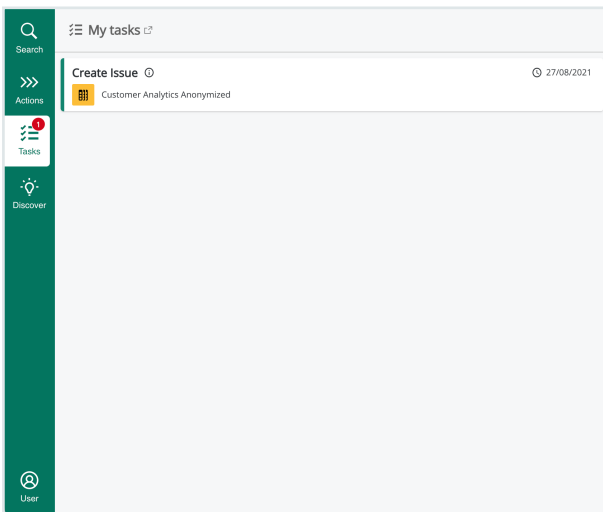

When you click a task, the details of the task appear along with the sidebar to complete the task. Complete the tasks by filling out the necessary fields and clicking a decision button.

Example

In the following image, you've been assigned a task to create an issue about an asset.

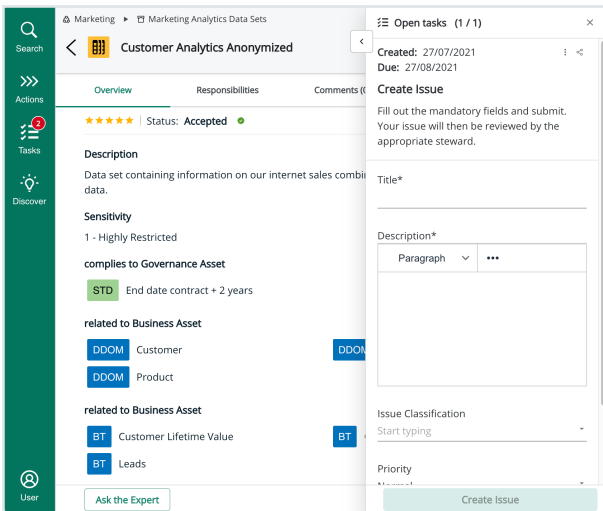

If the sidebar covers partly the description of the task, you can collapse the sidebar by clicking **X** in the top-right corner of the sidebar.

If you open an asset page for which you have to complete a task, you see the task icon (📅) in the header bar. Click that icon to open the task.

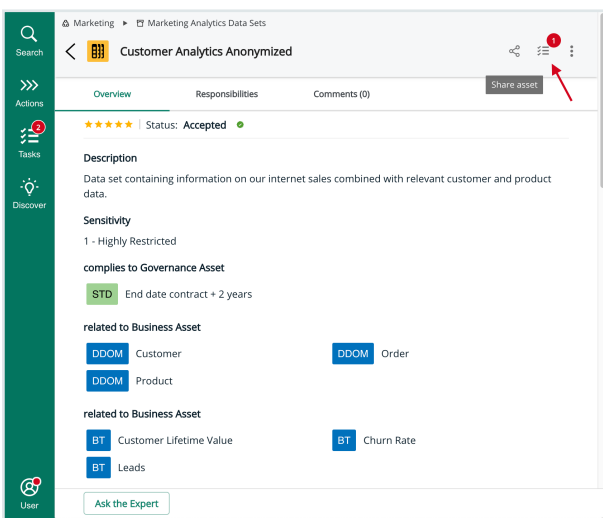

If the sidebar is too narrow, click **<** to expand it.

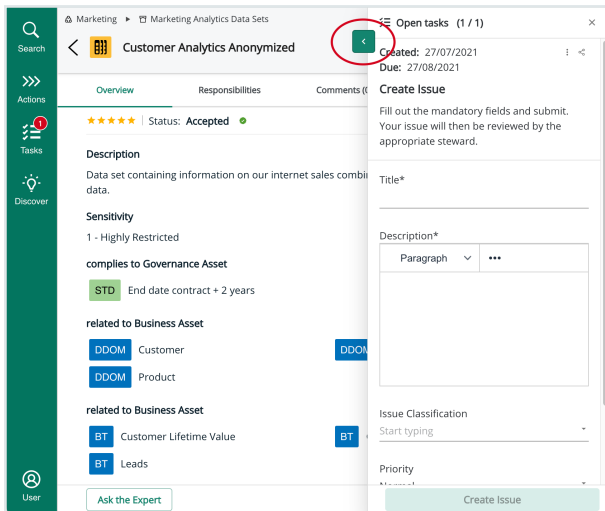

Click > to collapse the sidebar again.

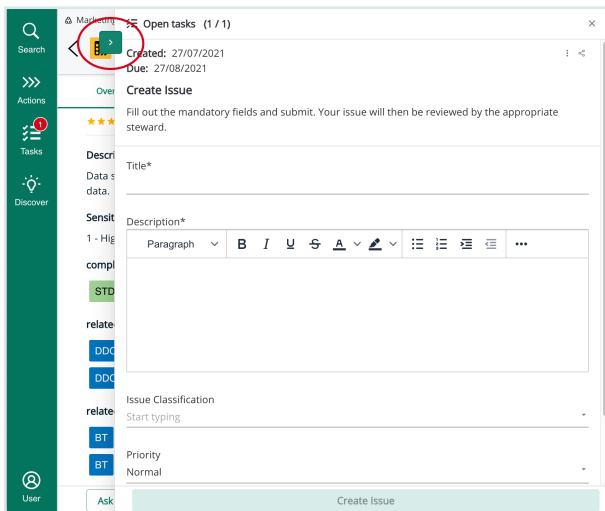

Reassign a task

If you are not the right person to complete a task that was assigned to you, you can reassign to it either another user, a role, or a user group.

Note A task can only be reassigned once.

1. In the navigation bar, select **Tasks**.
2. Select a task to open the details.

3. In the task sidebar, click **⋮** → **Reassign**.

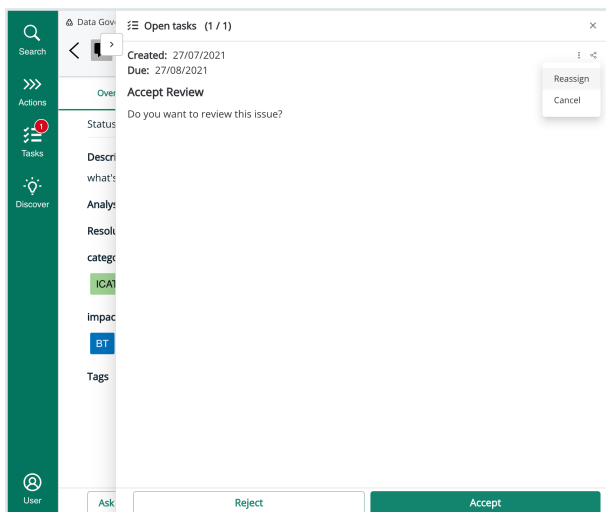

4. In the **Reassign Task** section, search for a user, role or group in the respective sections.

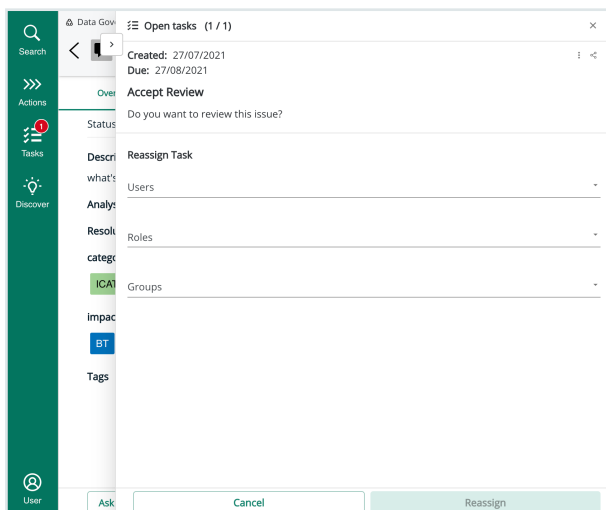

5. Click **Reassign**.

The task disappears from your task list.

Cancel a task

If a task is no longer necessary in a workflow, for example when multiple users were assigned a task but only one user has to complete a task, you can cancel it.

1. In the navigation bar, select **Tasks**.
2. Select a task to open the details.

3. In the task sidebar, click **⋮** → **Cancel**.

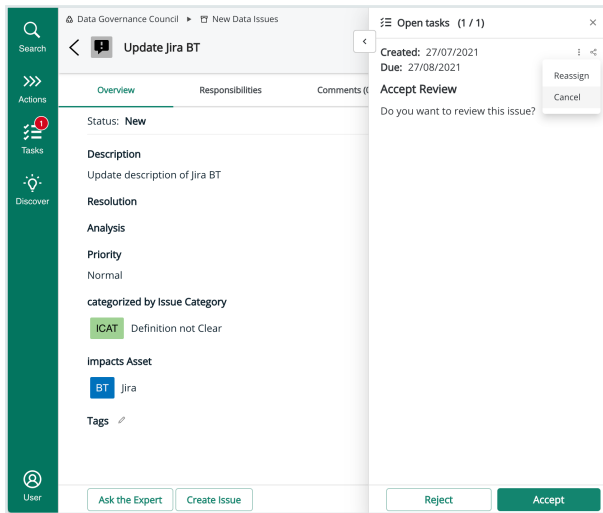

4. In the **Cancel Task** section, enter a reason for canceling the task.

Tip It is not mandatory to enter a reason.

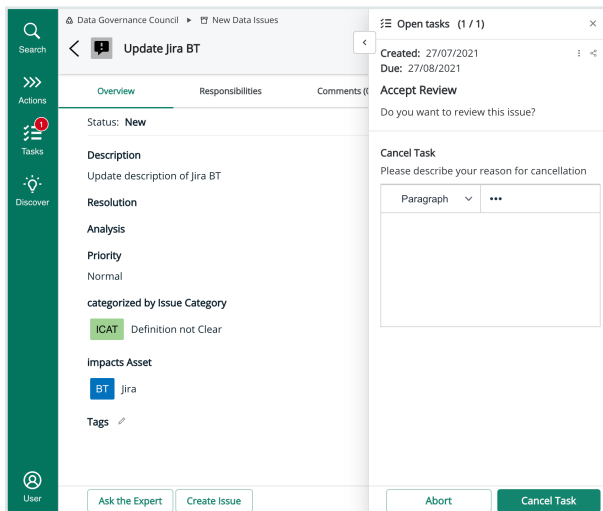

5. Click **Cancel Task**.

The task disappears from your task list.

Ratings

Ratings enable users to subjectively rate the quality of an asset, using a five-star rating system, and write a free-text review of the asset in support of the rating provided.

Enabling ratings

Ratings are enabled by asset type. When ratings are enabled for a particular asset type, users can [rate](#) any asset of that asset type.

Permissions

No particular license is needed to rate assets or to edit or delete your own ratings; you do, however, need certain resource permissions.

Permission	With this resource permission, you can...
Rating > Add	Rate any asset of an asset type for which the feature is enabled. With this permission, you can also edit or delete your own ratings.
Rating > Modify	Edit other users' ratings.
Rating > Remove	Delete other users' ratings.

View ratings

If ratings are enabled for an asset type and one or more ratings has been provided for an asset of that type, the associated ratings activity appears on the asset page.

On an asset page

Ratings information appears on the asset page of any asset with one or more ratings.

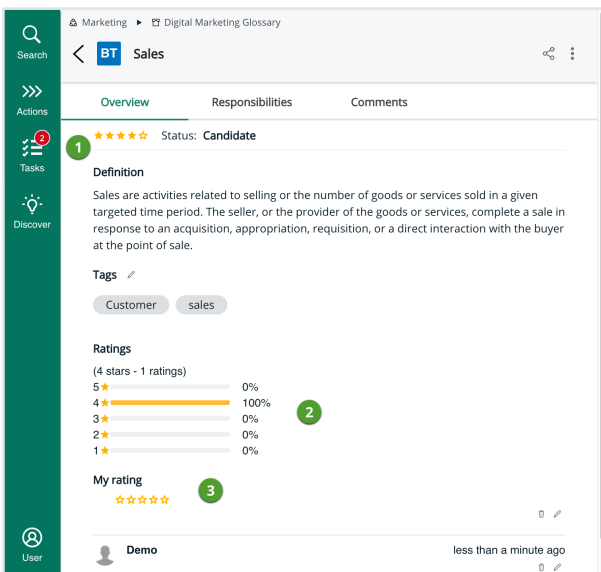

No.	Description
1	The average of all user ratings for that asset.
2	The global overview of the ratings for that asset including a horizontal bar chart representing the distribution of the ratings.
3	Your rating and review.

Rate an asset

You can rate any asset of an asset type for which ratings have been enabled.

You can [edit](#) or [delete](#) your ratings at any time.

Steps

1. Open the asset page of the asset that you want to rate.
2. On the **OVERVIEW** tab, scroll to the **Ratings** section.
3. In the **My rating** section, click the star that corresponds most closely to your opinion of the quality level of the asset.
The rating range is from one to five stars, with five representing the highest level of quality and one representing the lowest.
4. Optionally, enter a review of the asset in the text field.

Tip This collaborative feature is intended to help an organization improve the quality of its data and help users trust the quality of the data. As such, if you provide a rating of three stars or fewer, we strongly encourage you to provide a review to help the owner understand how the quality of the asset might be improved.

5. Click **Save**.
 - » The average user rating is recalculated.

Edit your ratings

You can edit or delete the ratings you've given if, for example, your opinion of the quality of an asset changes. It doesn't matter whether the rating has been given in Collibra Data Intelligence Cloud or in the Collibra for Desktop app.

Steps

1. Open the asset page of the asset for which you want to edit your rating.
2. On the **OVERVIEW** tab, scroll to the **Ratings** section.
3. In the **My rating** section, click .
 - Click the star that corresponds most closely to your opinion of the quality level of the asset.
 - Edit your review, if relevant.
4. Click **Save**
 - » The average user rating is recalculated.

Delete your ratings

If, for any reason, your opinion of the quality of an asset changes, you can [edit](#) or delete the ratings you've given, at any time.

Steps

1. Open the asset page of the asset for which you want to delete your rating.
2. On the **OVERVIEW** tab, scroll to the **Ratings** section.
3. At the right side of the rating that you want to delete, click .
4. Click **DELETE**, to confirm.
 - » The average user rating is recalculated.

Tableau assets

Tableau software is a data visualization software that helps you to see and understand your data. The Tableau integration enables you to register Tableau as a system in Collibra Data Intelligence Cloud and synchronize Tableau with Collibra. After synchronization, metadata of Tableau Server or Tableau Online are represented in Collibra by specific asset and domain types, retaining their original names.

In this section, we describe the Tableau operating model and give you an overview of the Tableau assets.

Tableau operating model	67
Tableau assets	68



Tableau operating model

Tableau assets in Collibra Data Intelligence Cloud are organized according the Tableau operating model. The following schema is a representation of this operating model, showing the relations between all Tableau assets.



Tableau term	Description
Site	A site is a stand-alone collection of content, such as projects, workbooks and users. Each site has its own URL and its own set of users.
Project	A project organizes related content resources. Content resources are workbooks, views and data sources.
Workbook	A workbook is a collection of views.
View	A view is a way to represent data.
Story	A story contains a sequence of worksheets or dashboards that work together to convey information.
Dashboard	A dashboard is a collection of views from multiple worksheets.

Tableau term	Description
Worksheet	A worksheet contains a single view, along with shelves, legends and the Data pane.
Tableau data sources	Tableau data sources consist of metadata that describe the connection information, information about how to access or refresh the data and customizations.
Tableau data model	Tableau data models are an abstraction for the physical implementation of databases, schemas, files, etc., used for Tableau report creation.
Tableau data entity	Tableau data entities are an abstraction of the physical implementation of database tables, used for Tableau report creation.
Tableau data attribute	Tableau data attributes define a property of a Tableau data entity.

Tableau assets

[Tableau assets](#) are assets that are created by synchronizing Collibra Data Intelligence Cloud with Tableau. For more information about this synchronization, see the [Collibra user guide](#).

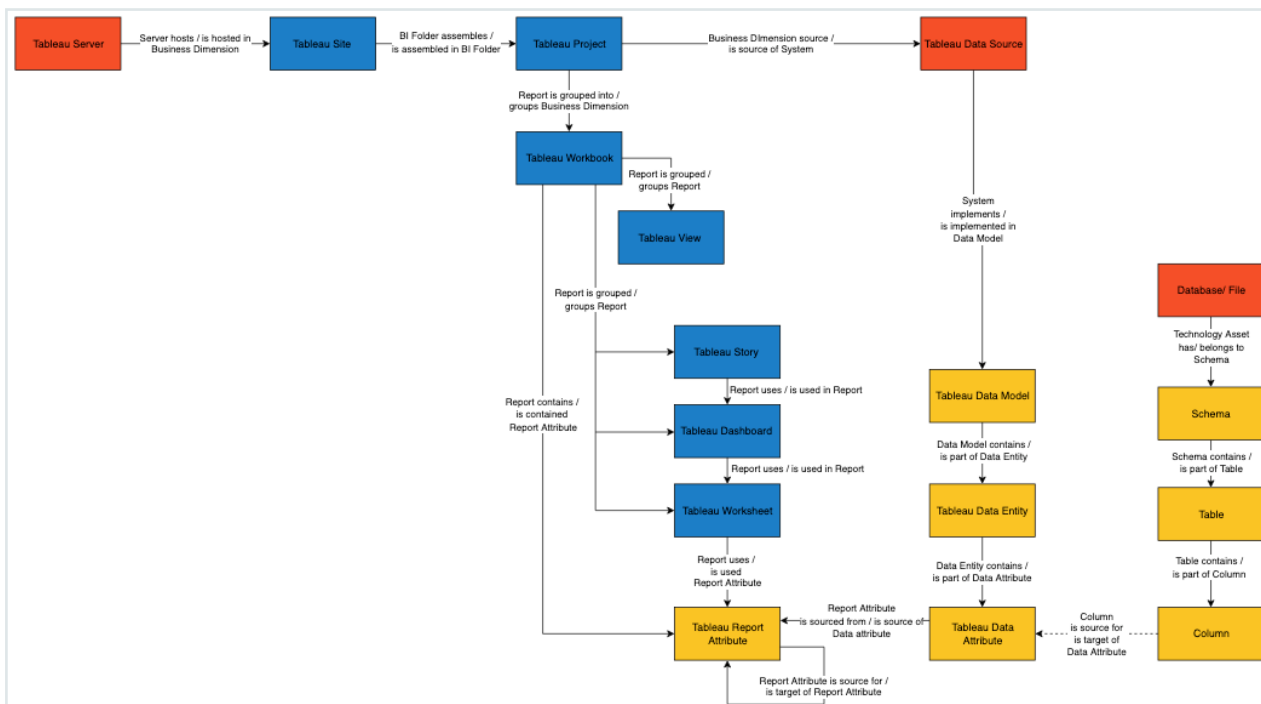
The **Overview** tab of Tableau assets in Collibra for Desktop shows the relations with other Tableau assets. When you click the related Tableau assets, you can browse through the whole Tableau operating model of the selected asset.

Example On a Tableau Workbook asset, you can see which reports it groups and

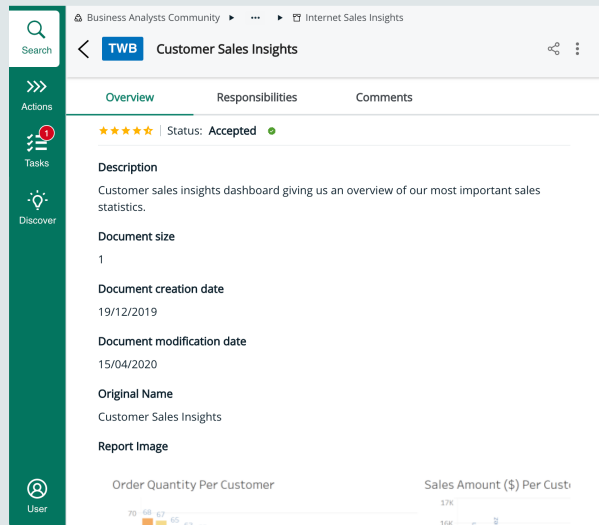

which attributes it contains.

If a dashboard may contain personal or sensitive information, you will see a warning at the top of the summary tab.

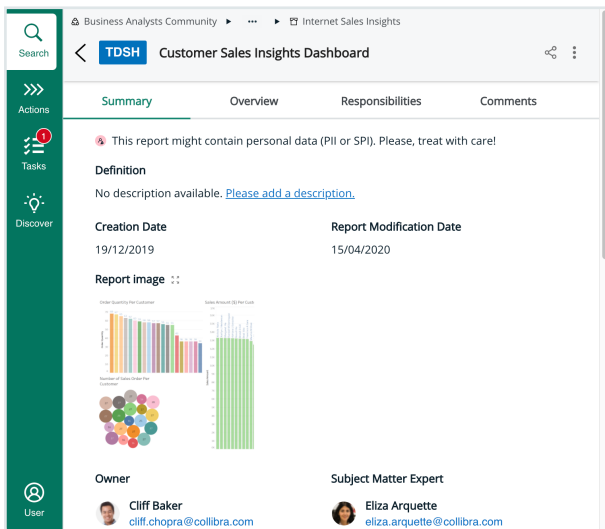

Power BI assets

Power BI is a business intelligence software that helps people see and understand their data. The Power BI integration enables you to register PowerBI as a system in Collibra Data Intelligence Cloud and synchronize Power BI with Collibra. After synchronization, metadata of Power BI are represented in Collibra by specific asset and domain types, retaining their original names.

In this section, we describe the Power BI operating model and give you an overview of the Power BI assets.

Power BI operating model	71
Power BI assets	72



Power BI operating model

Power BI assets in Collibra Data Intelligence Cloud are organized according the Power BI operating model. The following schema is a representation of this operating model, showing the relations between all Power BI assets.

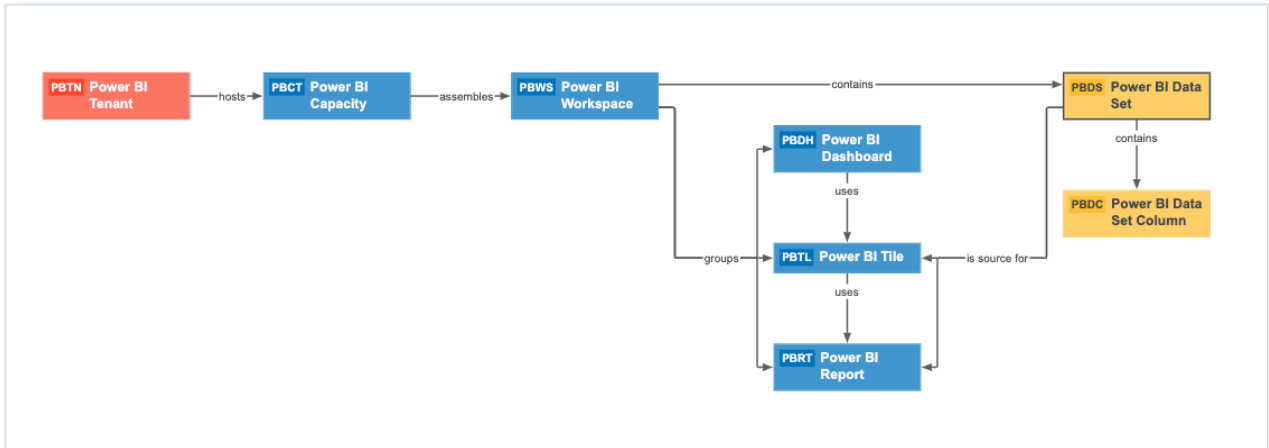

Power BI term	Description
Power BI Capacity	A resource that hosts Power BI Workspaces.
Power BI Dashboard	A collection of Power BI tiles with metrics from one or more Reports and Data Sets.
Power BI Data Set	A collection of data that is used to create a Power BI report.
Power BI Data Set Column	A column in a Power BI Data Set.
Power BI Report	A detailed view of a Power BI Data Set, with visualizations of findings and insights.
Power BI Tenant	A platform to create dashboards and rich visualizations.

Power BI term	Description
Power BI Tile	An element representing data on the Power BI Dashboard.
Power BI Workspace	A collection of Power BI Dashboards, Reports and Data Sets.

Power BI assets

Power BI operating model are assets that are created by synchronizing Collibra Data Intelligence Cloud with Power BI. For more information about this synchronization, see the Collibra user guide.

The **Overview** tab of Power BI assets in Collibra for Desktop shows the relations with other Power BI assets. When you click the related Power BI assets, you can browse through the whole Power BI operating model of the selected asset.

Example On a Power BI Dashboard asset, you can see all the components that are

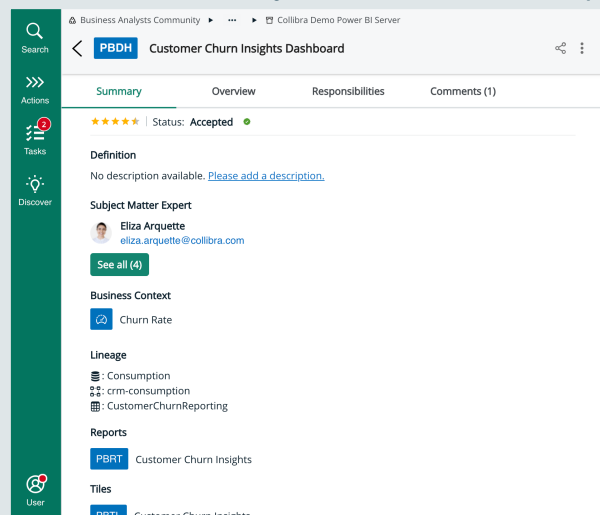

used on the dashboard.

If a Power BI asset may contain personal or sensitive information, you will see a warning at the top of the Summary tab.

Looker assets

Looker is a business intelligence software that helps people see and understand their data. It helps you explore, share and visualize your data so that you can make better business decisions.

In this section, we describe the Looker operating model and give you an overview of the Looker assets.

Looker operating model	75
-------------------------------------	-----------



Looker operating model

Note

- The assets have the same names as their counterparts in Looker. Full names and Display names cannot be changed in Catalog.
- Asset types are only created if you have all specific Looker and Catalog permissions.
- All Looker asset types are created in the same domain.
- Relations that were manually created between Looker assets and other assets via a relation type in the Looker operating model are deleted after a refresh of the Looker metadata.

Looker metadata overview

The following image shows the relations between Looker asset types.

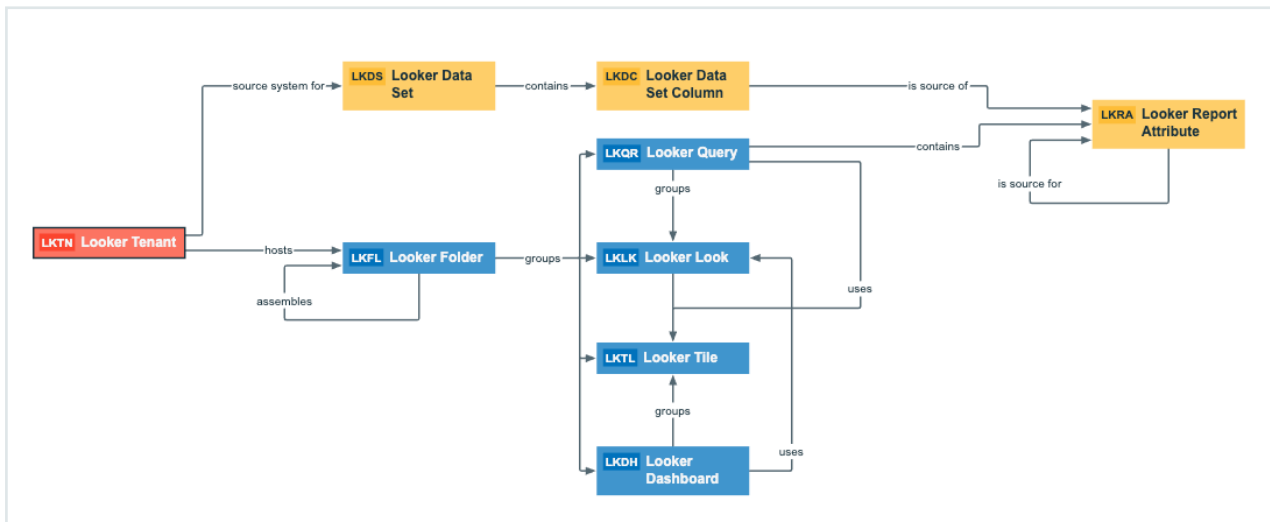

Harvested metadata per asset type

The following table shows the harvested Looker metadata for each Looker asset type.

Asset type	Harvested Looker metadata in Catalog
Looker Dashboard	<ul style="list-style-type: none"> • Full name • Display name • Description • Visit count • Favorites count • Document creation date • Document last accessed date • Business Dimension groups / is grouped into Report • Report uses / is used in Report • Report groups / is grouped into Report. • Report related to / impacted by Business Asset
Looker Data Set	<ul style="list-style-type: none"> • Full name • Display name • Description • Technology Asset source system for / source system Data Asset • Data Set contains / is part of Data Element
Looker Data Set Column	<ul style="list-style-type: none"> • Full name • Display name • Description • Data Set contains / is part of Data Element • Report Attribute sourced from / is source of Data Attribute
Looker Folder	<ul style="list-style-type: none"> • Full name • Display name • Document creation date • Server hosts / is hosted in Business Dimension • BI Folder assembles / is assembled in BI Folder • Business Dimension groups / is grouped into Report

Asset type	Harvested Looker metadata in Catalog
Looker Look	<ul style="list-style-type: none"> • Full name • Display name • Description • URL • Visits count • Favorites count • Document creation date • Document modification date • Document last accessed date • Business Dimension groups / is grouped into Report • Report uses / is used in Report • Report groups / is grouped into Report
Looker Report Attribute	<ul style="list-style-type: none"> • Full name • Display name • Report Attribute contained in / contains Report • Report Attribute sourced from / is source of Data Attribute
Looker Query	<ul style="list-style-type: none"> • Full name • Display name • Business Dimension groups / is grouped into Report • Report uses / is used in Report • Report Attribute contained in / contains Report
Looker Tenant	<ul style="list-style-type: none"> • Full name • Display name • Description • Server hosts / is hosted in Business Dimension • Technology Asset source system for / source system Data Asset
Looker Tile	<ul style="list-style-type: none"> • Full name • Display name • Business Dimension groups / is grouped into Report • Report uses / is used in Report

App settings

In the [Collibra for Desktop settings](#), you can edit options such as tracking and filters.

Via [Collibra Console](#) of the Collibra Data Intelligence Cloud environment, you can also edit settings. These settings can be overruled by the settings that are set in Collibra for Desktop.

Settings in Collibra for Desktop

In the app settings, you can set your keyboard shortcut, proxy server information and so on. To access the settings, click  **User** in the bottom-left corner of the app and then select **Settings**.

Tip You can also define the settings in [Collibra Console](#). You need at least Collibra Data Intelligence Cloud 2021.01 and Collibra for Desktop 1.2.1.

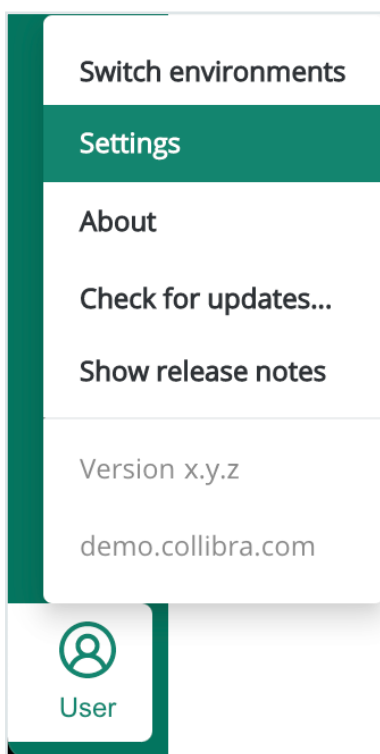

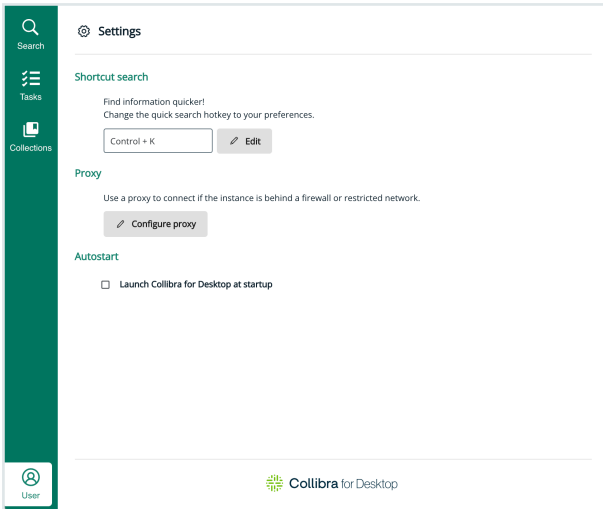

In the Collibra for Desktop settings, you can edit the following options:

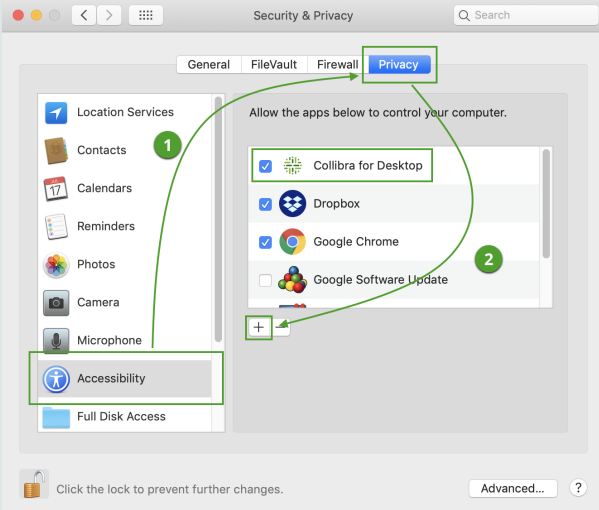
Setting	Description
<p>Shortcut search</p>	<p>The keyboard shortcut to search selected text in Collibra Data Intelligence Cloud from within your browser or another application.</p> <p>Specifying a keyboard shortcut in the app will overrule any keyboard shortcut that might have been applied by your administrator via the web settings.</p> <div data-bbox="427 584 1422 1301" style="border: 1px solid #ccc; padding: 10px; margin: 10px 0;"> <p>Tip Add Collibra for Desktop to the list of apps that are allowed to control your computer, via System Preferences → Security & Privacy → Accessibility and then the Privacy tab.</p>  <p>The screenshot shows the 'Security & Privacy' window with the 'Privacy' tab selected. On the left sidebar, 'Accessibility' is highlighted with a green box and a '1'. In the main content area, 'Collibra for Desktop' is checked and highlighted with a green box and a '2'. A green arrow points from the '1' to the '2', indicating the path to add the app. A '+' button is also visible at the bottom of the app list.</p> </div> <p>Note If Allow User Configuration in Collibra Console is disabled, this option is not available.</p>
<p>Proxy</p>	<p>The configuration settings if there is a proxy server to connect to Collibra.</p> <ul style="list-style-type: none"> • Proxy: Proxy server address in the format URL:port. • Username: The username to connect to the proxy server, if required. • Password: The password that corresponds with the given username.
<p>Autostart</p>	<p>The option to start Collibra for Desktop when you sign in to your operating system.</p> <p>Keep in mind that you still have to sign in to the app.</p>

Note It is possible that you cannot edit the settings due to limitations, configured in Collibra Console of your Collibra environment or during an unattended installation.

Settings in Collibra Console

1. Open Collibra Console of your Collibra environment.
2. In the tab pane, click the **Data Governance Center** service of your environment.
3. Click **Configuration**.
4. Click **Edit configuration**.
5. Scroll to the **Everywhere Desktop configuration** section.
6. Edit the options:

Setting	Description
Default search filter	<p>The filter that is applied, by default, to search results. The value must be the UUID of the filter.</p> <p>Note Specifying a default search filter in the application will override the default filter that you specify in Collibra Console.</p>
Custom search box placeholder	<p>Placeholder text that appears in the Search field before a user enters search text.</p> <p>The default text is "Search in Collibra".</p>
Shortcut search	<p>The setting to enable the use of a keyboard shortcut to search for selected text in Collibra Data Intelligence Cloud.</p> <ul style="list-style-type: none"> ○ ✓ True (default): Users can use the keyboard shortcut you specify in the following setting to search in Collibra for Desktop. ○ ✗ False: Keyboard shortcut is disabled.

Setting	Description
Custom shortcut search	<p>The keyboard shortcut to search for selected text in Collibra Data Intelligence Cloud from any application that you are using.</p> <div data-bbox="608 465 1422 645" style="background-color: #f0f0f0; padding: 5px;"> <p>Tip The keyboard shortcut has to be a combination of Control, Alt or Shift with one letter or number. On macOS you can also use the Command key.</p> </div> <div data-bbox="608 678 1422 969" style="background-color: #f0f0f0; padding: 5px;"> <p>Note</p> <ul style="list-style-type: none"> ◦ The keyboard shortcut only works if Shortcut search is enabled. ◦ Specifying a keyboard shortcut in the application will override the shortcut that you specify here in Collibra Console. </div>
Enable Auto Hyperlinking	<p>The setting to enable automatic hyperlinking within Collibra for Desktop.</p> <p>With this option enabled, the name of an asset automatically becomes a hyperlink when you fill out a text attribute.</p> <p>This option only works if the Enable hyperlinking option in Collibra Console is also enabled.</p>
Enable Workflows	<p>The setting to enable workflows in Collibra for Desktop.</p> <p>This allows you to complete tasks or start a workflow in the app. The available workflows depend on the ones that you add to the Global workflows and Asset workflow configuration.</p>

Setting	Description
Recommender	<p>The Recommender helps users by suggesting relevant business assets and data sets, based on certain relation types and the past actions of similar users.</p> <ul style="list-style-type: none"> ✓ True: Recommender is enabled. ✗ False (default): Recommender is disabled. <p>This feature only works if Analytics is enabled. You can enable Analytics in section 1 General of the DGC service configuration.</p>
Auto-updater	<p>The setting to enable automatic upgrades when a new version is available.</p> <ul style="list-style-type: none"> ✓ True (default): Collibra for Desktop is automatically upgraded when a new version is available. ✗ False: You need to manually upgrade Collibra for Desktop when a new version is available. <p>Note If you enable automatic updates, you have to whitelist the S3 bucket collibra-otg-desktop-installers in the region eu-west-1.</p>
Allow User Configuration	<p>The setting enable users to edit personal settings in Collibra for Desktop.</p> <ul style="list-style-type: none"> ✓ True (default): Users can edit personal settings. ✗ False: Users cannot edit personal settings. <p>If this setting is disabled, the selecting a keyboard shortcut is not possible in the app settings, only via Collibra Console.</p>
Application Title (Windows only)	<p>Option to edit the window name that appears in the title bar of the application.</p> <p>If you don't define this setting, the value is Collibra for Desktop.</p> <p>This setting is only applicable on Windows.</p>

Setting	Description
Logo	<p>Option to change the logo in the sign-in window of Collibra for Desktop.</p> <p>Use a public URL to the logo.</p>
Primary color	<p>Option to change the color of the navigation bar in Collibra for Desktop.</p> <p>You can set a color with the hex code (<code>#00008B</code>), rgb or rgba code (<code>rgb(0,0,139)</code>) or hsl or hsla code (<code>hsl(240,100%,27%)</code>).</p> <div style="background-color: #e0e0e0; padding: 5px; border-left: 2px solid #00a651;"> <p>Tip Avoid using light colors to avoid readability issues.</p> </div>
Secondary color	<p>Option to change the color of the ribbon of a highlighted section in for example the search results.</p>
Global workflows	<p>The list of workflows that is available in the app's main menu.</p> <p>Enter the UUIDs of the workflows. An example workflow could be "Create issue".</p>
Asset workflow	<p>The list of workflows that is available on an asset page in the app.</p> <p>Enter the UUIDs of the workflows. An example workflow could be "Ask the expert".</p>
No search result workflows	<p>The workflows that are available if there are no search results found.</p> <p>Enter the UUIDs of the workflows. An example workflow could be "Propose new business term".</p>

Setting	Description
Enable autostart	<p>Option to automatically start Collibra for Desktop when signing in to your operating system.</p> <ul style="list-style-type: none">○ ✓ True: The app starts automatically when signing in to your operating system.○ ✗ False (default): The app does not start automatically. <p>If you have set this option in the Collibra for Desktop settings, this option is neglected.</p>

7. Click **Save all**.

Note If you use Collibra for Desktop with more than one Collibra environment, the settings of the last used environment are applied. Note that settings in the app take precedence over the ones in Collibra Console.

Set the search keyboard shortcut



The keyboard shortcut allows you to quickly start a search query by highlighting text in any application on your computer and then pressing the defined keyboard shortcut.

The default keyboard shortcut is `Control + K`.

In this section, we describe how you can edit the keyboard shortcut.

Via Collibra for Desktop settings

You can edit the keyboard shortcut via the Collibra for Desktop settings only if [Allow User Configuration](#) is enabled in Collibra Console.

1. Open the Collibra for Desktop app.
2. In the bottom-left corner, click  **User** → **Settings**.
3. In the **Shortcut search section**, click .
 - » The **Edit key shortcut** dialog box appears. It shows the current shortcut.
4. Press the desired keyboard shortcut.
 - On Windows, you can combine `Control`, `Alt` and `Shift` with one letter, number or non-alphanumerical character.
 - On macOS, you can use `Control`, `Command` and `Shift` with one letter, number or non-alphanumerical character.

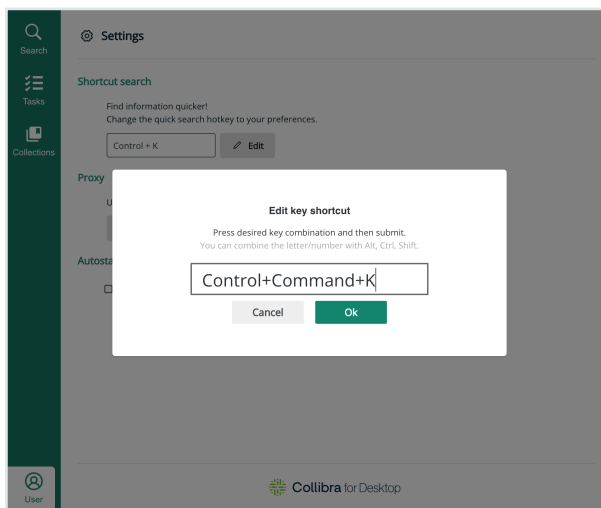

- » The new keyboard shortcut appears.

Note You cannot use a single quote or a backslash in your keyboard shortcut. We also strongly recommend that you don't use special keyboard keys, such as PrintScreen, Pause or the arrow keys.

5. Click **OK**.
 - » A notification in the bottom-left corner indicates that the setting is saved.
6. Close the **Settings** page.

Tip Add Collibra for Desktop to the list of apps that are allowed to control your computer, via **System Preferences** → **Security & Privacy** → **Accessibility** and then the **Privacy** tab.



Via Collibra Console

If the keyboard shortcut is set in the Collibra for Desktop settings, the update via Collibra Console has no effect.

1. Open Collibra Console.
2. In the tab pane, expand an environment to show its services.
3. Click the **Data Governance Center** service of that environment.
4. Click **Configuration**.
5. Click **Edit configuration**.
6. Scroll to the **Everywhere Desktop configuration** section.

7. In the **Custom Shortcut Search** field, enter the desired keyboard shortcut. Use the + symbol to combine keys.
 - a. On Windows, you can combine `Control`, `Alt` and `Shift` with one letter, number or non-alphanumerical character, for example `Control+Alt+K`.
 - b. On macOS, you can use `Control`, `Command` and `Shift` with one letter, number or non-alphanumerical character, for example `Command+Shift+K`.
8. Click **Save all** to apply the changes.
9. Restart Collibra for Desktop.

What's next?

You can use the new keyboard shortcut to start new search queries.

Change the Collibra for Desktop colors

If you want the Collibra for Desktop look to be more in line with your company brand, you can change the colors of the app.

1. Open Collibra Console.
2. In the tab pane, expand an environment to show its services.
3. Click the **Data Governance Center** service of that environment.
4. Click **Configuration**.
5. Click **Edit configuration**.
6. Scroll to the **Everywhere Desktop configuration** section.
7. In the **Primary color** field, enter the color that you want to use.

The primary color is used for the banner of the sign-in window and the navigation bar.

Specify a color that contrasts with the main page of the app.

Accepted color codes are hex (`#nnnnnn`), `rgb`, `rgba`, `hsl` or `hsla`.

Example

- hex: `#00008B`
- `rgb`, `rgb(0, 0, 139)`. Spaces after the comma can be omitted.
- `rgba`: `rgba(0,0,139,0.5)`
- `hsl`: `hsl(240, 100%, 27%)` Spaces after the comma can be omitted.
- `hsla`: `hsla(240, 100%, 27%, 0.5)`

8. In the **Secondary color** field, enter the color that you want to use.
The secondary color is used as ribbon when you hover over a search result. Specify a color that contrasts with the primary color.
9. Click **Save all** to apply the changes.
10. Restart Collibra for Desktop.

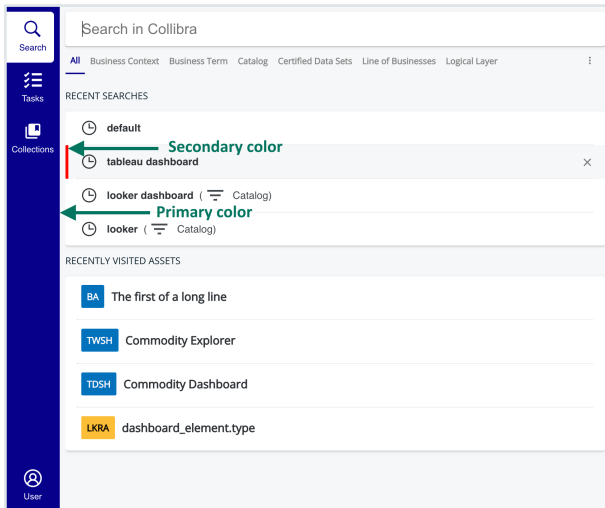

Add your own logo to the sign-in window

When you sign in to Collibra for Desktop or when you switch environments, you see the Collibra logo at the top of the page.

In this section, you learn how to replace that logo by your own.

Prerequisites

You have the URL to the image that you want to use.

Steps

1. Open Collibra Console.
2. In the tab pane, expand an environment to show its services.
3. Click the **Data Governance Center** service of that environment.
4. Click **Configuration**.
5. Click **Edit configuration**.

6. Scroll to the **Everywhere Desktop configuration** section.
7. In the **Logo** field, enter the URL to the image that you want to use.
8. Click **Save all** to apply the changes.
9. Restart Collibra for Desktop.

